

CIRCUIT RACE APPENDIX

1st Category – Racing Cars

Formula Ford 1600 – Technical Regulations

Modified Article	Date of Application	Date of Publication

PREAMBLE

The Formula Ford Association Incorporated (FFA) is recognised by *Motorsport Australia* as the sole entity representing competitors in Formula Ford 1600 competition. The FFA shall be responsible for consultation processes within its membership and with other interested parties as may be appropriate from time to time. *Motorsport Australia* is ultimately responsible for the approval of the regulations and changes thereto, and responsible for publishing the regulations and associated bulletins as necessary.

Prior to being issued with a log book, each Formula Ford car must be issued with a certificate of origin. For details of the certificate of origin please contact the FFA.

The Formula Ford Association Incorporated (FFA)

(ABN: 42 015 166 048)

Administrator: Phil Marrinon

c/- 13 Aintree Ave

MULGRAVE, VIC. 3170

Mob: 0422 840 300

Email: admin@formulaford.org.au

DEFINITION

1.1 GENERAL

Formula Ford 1600 is open to single-seater cars with open coachwork as defined by *Motorsport Australia* and complying with its Vehicle Regulations, using standard 1600cc crossflow engines of the types described in Article 2 below (refer also to Schedule A, B and C – see Technical Appendix in the *Motorsport Australia Manual* – and the specifications for 1st Category - Racing Cars).

ENGINE

2.1 GENERAL

Only the Ford 1600cc crossflow unit fitted to the Capri XL and the Escort Ghia (1975) is permissible. See Ford Motor Co. of Australia Bulletins: “1971 Capri” (January 1971) and “1975 Escort Ghia” (October 1974). Alternative replacement blocks to the original 711M 6015BA block is permissible as listed below:

Block number	AX 831C6015R34 Ford Racing “711” part No. M-6010-16K
--------------	--

- (a) Bore and Stroke:

The nominal bore will be 81mm and stroke 77.62mm.

2.2 Engine Mounting:

Engines will be mounted upright, and aligned fore and aft in the chassis, save that cars manufactured prior to 1 January, 1988, and complying with the requirements published in the 1987 FFA Handbook, may continue to race until further notice.

2.3 Material:

- (a) The addition of any material, be it metal, plastic or composite etc, by any means be it welding, bonding, encapsulation or encasement to any component is prohibited. However, specific repair of castings may be allowed with written approval of a FFA Technical Commissioner.

- (b) Balancing of reciprocating and rotating parts is permitted only by the removal of metal from locations so provided by the manufacturer.

2.4 Engine Ancillaries:

- (a) Non-standard rocker covers are permitted provided that they in no way improve the performance of the engine. Water passages are not permitted in rocker covers.
- (b) Standard valve spring retainers must be used. Only single valve springs are permitted. Shims are permitted, otherwise valve springs are free.
- (c) Pushrods, rockers, tappets, pedestals and shaft must remain standard. Re-profiling of the valve stem contact pad on the rocker arm is permitted, provided that the maximum specified lift at the spring cap is not exceeded.
- (d) No polishing, profiling, lightening or other modification to the standard part is permitted, save that the rocker pedestals may be shimmed (with a parallel strip of steel) to compensate for the surfacing of the cylinder head.
- (e) Cam followers may be replaced by after-market units of equivalent design and standard dimensions.

2.5 Carburettor:

Type: Weber 32/36 DGV or DGAV (from 1600 GT Kent or 2000 NE engine).

Number on engine	1
Number of main venturi	2
Max. diameter of main venturi	26.0/27.0mm
Max. diameter of carburettor outlet to inlet manifold	32.0/36.0mm

- (a) It is permitted to change jets, open both throttles together, remove cold start devices and diffuser bar, fit internal and external surge compensation pipes and to remove or modify the power valve system to accommodate such pipes. It is permitted to remove the seals from emission control carburettors.
- (b) No other modifications are permitted.
- (c) Chokes must remain standard and no polishing or re-profiling is permitted. Any means of reducing intake air temperature is prohibited. Any form of water injection is prohibited.
- (d) Carburettor to inlet manifold gasket: Ford part No 1663371, Ford part no. XE 9447A or Ford part No. 76XF 9447AA. Maximum thickness 6.7mm.
- (e) The air cleaner may be removed or replaced and a trumpet fitted.

2.6 Exhaust:

- (a) The exhaust system and manifold are free, subject to their compliance with the vehicle dimension restrictions laid out in figure 1 of these regulations.
- (b) A muffler complying with the requirements of Motorsport Australia must be fitted at all times during practice and racing.

2.7 Lubrication System

- (a) The lubrication system, external to the engine, is free. Existing standard production oilways, linings or oil grooves may be enlarged or reduced but no additional ones are permitted. Standard friction surfaces must remain unchanged.
- (b) Dry sump is permitted. Oil coolers are free.

2.8 Cooling System:

- (a) A liquid cooling system is mandatory. Radiator and water pump are free, save that the water pump must be in the original location
- (b) The radiator if housed in or incorporating a cool air scoop or deflector must comply with the bodywork regulations.

2.9 Camshaft:

- (a) The only permitted camshaft is either an original "period" Ford camshaft, a contemporary Ford production camshaft, or a billet camshaft. The camshaft shall be registered through the Formula Ford Association Inc, being part no. FFAC1 - nnn (nnn representing a three-digit number unique to each individual camshaft) which number is stamped on the camshaft.

- (b) The camshaft will be ground from a master cam approved by Motorsport Australia and held by the FFA. Each unit will be the subject of a "cam doctor" report.
- (c) The min. base circle diameter will be 25.900mm.
- (d) "Tufriding®", "Parkerising®" and Nitriding are permitted. Shot peening, shot blasting or polishing are prohibited. Offset dowels are permitted.
- (e) Notwithstanding anything else in this Regulation, modification of the camshaft is expressly prohibited.
- (f) Camshafts may be tested and measured on an approved "cam doctor" as nominated by FFA or Motorsport Australia and may be compared with the original report for that camshaft and/or with a report from the master camshaft.
 - (i) Maximum permitted lift at the top of the pushrod:
 - (A) - inlet: 5.917mm
 - (B) - exhaust: 5.943mm
 - (ii) Maximum permitted lift at the spring cap with zero tappet clearance:
 - (A) - inlet: 9.042mm
 - (B) - exhaust: 9.093mm
- (g) Measurement of Lift:
 - (i) Where any engine valves, up to a maximum of two being inlet and/or exhaust, are found to have lift in excess of that permitted, then the lift on all four inlet valves or all four exhaust valves is to be added and divided by four.
 - (ii) The average lift as determined may not exceed that permitted for the relevant valve.
 - (iii) If more than two valves are measured as having excess lift, then the foregoing does not apply and the engine is prima facie ineligible.

2.10 Crankshaft:

- (a) The crankshaft must be either standard Ford production crankshaft, or SCAT cast steel crankshaft, part no. 9-FF1600. Localised spot machining of the outer (ie, larger) circumference of the counterweights, or the outer face of the inner (ie, smaller) circumference of the big end surfaces may be undertaken only to achieve balance.
- (b) A crankshaft may be ground to reclaim damaged surfaces in accordance with normal reconditioning procedures, provided always that the stroke is standard.
- (c) Tufriding®, nitriding, shot peening and shot blasting are permitted. Polishing is prohibited.
- (d) Minimum weight:
 - (i) Standard crankshaft: 11.1kg
 - (ii) SCAT crankshaft: 11.5kg
- (e) Crankshaft pulley is free as is the toothed belt drive. It is not permitted to alter the number of bearings or fit bearings of less than standard production width.
- (f) Standard oversize and undersize bearings are permitted.
- (g) Main bearing cap bolts may be replaced by ferrous bolts of similar type and dimension.
- (h) It is permitted to dowel the rear crank seal housing and to machine the rear seal housing to allow external removal and fitment of the seal.

2.11 Flywheel and Clutch:

- (a) The flywheel and clutch pressure plate assembly must be standard components. The ring gear is free but must be directly fitted to the flywheel and must have a minimum ID of 215mm.
- (b) It is permissible to mill or machine the flywheel only to achieve minimum weight and balance.
- (c) For rectification the clutch mating face may be resurfaced. It is permitted to use a similar pattern replacement clutch (i.e. conventional single diaphragm spring) driven plate with more than one shock absorber spring. Organic friction material only is permitted.
- (d) Racing clutches are prohibited.

- (e) Flywheel bolts are free. Locating dowels are permitted. The addition of a single flat washer under the head of each bolt is permitted. Maximum dimensions for these washers are:
- (f) It is permitted to secure the starter ring to the flywheel.

ID	9.7mm
OD	16mm
Thickness	2.5mm

- (g) **Minimum permitted weight** of the flywheel and clutch assembly (i.e. complete unit, including flywheel to crankshaft mounting bolts) is **11.79kg**.

2.12 Compression ratio:

- (a) The maximum compression ratio will be controlled as follows:
 - (i) minimum combustion volume in piston 41cc (with piston at TDC in cylinder and no account taken of volume down to top piston ring), measured in "as run" condition (eg, without removal of carbon);
 - (ii) standard Ford cylinder head gasket part no. 781 M6051 AA, 931M6051AA or ACL Part No. AS 590 or standard replacement cylinder head gasket is permitted and shall comply to the following specification;
 - (A) minimum compression thickness: 0.85mm
 - (B) minimum diameter of cylinder aperture: 82.5mm
- (b) pistons must not protrude above the cylinder block face at TDC. The cylinder block surface may be machined;
- (c) maximum permitted protrusion of the valves into the combustion chamber:
 - (i) 1.2mm notwithstanding the requirements herein and in other relevant regulations, including those of cylinder head, pistons, cylinder blocks etc. and engines prepared for competition in accordance with the eligibility requirements published in the 1987 FFA Handbook may continue to race until further notice provided such engines comply with all such requirements.
 - (ii) It is not permissible for engine specifications to be selected from both these and earlier Regulations.

2.13 Head and Block

- (a) It is permissible to reshape inlet and exhaust ports by removal of metal within limits.
- (b) Any chamfering of ports at manifold faces will be included in port measurements. Addition of material in any form is prohibited.
- (c) Maximum port diameter at inlet manifold face:
 - (i) inlet: 36.12mm
 - (ii) exhaust: 29.41mm
- (d) Inlet and exhaust port diameter may be exceeded in isolated spots if the original casting is visible and untouched at the gasket face.
- (e) It is permitted, as a means of repair, to replace damaged valve guides to standard dimensions, and to fit hardened valve seat inserts, with a maximum depth of 8.5mm.
- (f) It is permitted, as a means of repair, to replace damaged cylinder bores with cast iron cylinder liners, all to standard dimensions.
- (g) Localised machining of the cylinder block is permitted to allow fitting of a dry sump system.
- (h) The crankcase breather may be altered or removed, but all breathers must discharge to a catch tank. The block may be machined to maintain deck height.
- (i) Pedestal and cylinder head bolts may be replaced by ferrous bolts of similar type and dimension.

2.14 INLET MANIFOLD

- (a) Standard Ford production inlet manifold for 1600 GT Kent engine, unmodified in any way must be used, save;

- (i) that it is permissible to match the manifold ports to the cylinder head ports by machining the manifold ports to a distance not exceeding 35mm from the manifold head inner face, including polishing.
- (ii) The mounting holes of the inlet manifold may be enlarged and/or bushed to achieve adjustment.
- (iii) Dowelling of the inlet manifold to the cylinder head is permitted.
- (iv) The carburettor seat face may be machined to horizontal in the fore and aft plane, save for those cars exempted in Regulation 2.1(c) which may have the carburettor seat face machined to the horizontal in all planes. The water passage in the inlet manifold may be blanked off or plugged.
- (v) The manifold may be machined externally sufficiently to clear the throttle mechanism in the case of both throttles being opened together.
- (vi) The inlet manifold to cylinder head gasket shall be Ford part no. EEG 64, 931M9441AA, ACL part no. JA613B or a standard replacement inlet manifold gasket and shall comply with the following specification.
- (vii) Maximum thickness shall be 0.86mm
- (viii) The brake vacuum entry in the inlet manifold may be blanked off or plugged. Other than as provided above, manifolds must remain standard.

2.15 PISTONS:

- (a) Pistons must be standard Ford production pistons or FFI piston, part numbers 9096466 or 9096469, unmodified in any way except for balancing and as detailed herein.
- (b) All three piston rings must be fitted, which must be of standard production or similar pattern replacements; ie,
 - (i) the compression rings must be one-piece, single-material type with conventional plain gaps. Chromium plating of the top ring is optional.
 - (ii) The oil control rings must be either single-piece twin land or apex threepiece (two rails and an expander) type.
 - (iii) Molybdenum-faced top compression rings are permitted.
 - (iv) Machining of the top and bottom of the crown (including the bowl) and the gudgeon pin bosses of the piston to achieve volumetric and weight balance and minimum weight is permitted.
 - (v) Minimum weight complete with pistons rings and gudgeon pin: 515g
 - (vi) Weight of gudgeon pin: 113g + - 2g

2.16 VALVES:

- (a) Valves must remain standard. No re-profiling or polishing is permitted. The original 45° seat angle must be maintained.
- (b) Distance apart at the centres: 39.12 ± 0.5mm
- (c) Maximum face diameter:
 - (i) inlet 39.62mm
 - (ii) exhaust 34.00mm
- (d) Valve stem seals are optional.
- (e) Valves with oversize valve stems are permitted.
- (f) The following valves are permitted:
 - (i) standard Ford Motor Co. replacement parts
 - (ii) FFI valves:
 - (A) inlet part number M91596693
 - (B) exhaust part number M96077327

2.17 CONNECTING RODS:

- (a) Connecting rods must be standard Ford parts. Machining is permitted to remove metal from the balancing bosses on the big end cap and at the little end to achieve balance only. Polishing is prohibited.
- (b) Connecting rod bolts may be replaced by ferrous bolts of similar type and dimension.
- (c) Minimum weight (including bolts and small end bearing): 640g

2.18 TIMING CHAIN:

- (a) The timing chain cover may be altered or replaced. The timing chain tensioner and tensioner pad may be replaced with an after-market component, provided the replacements are of similar design and operate in an identical manner to the original component.
- (b) Mechanical tachometer drives may be fitted.

2.19 ASSEMBLY:

- (a) The use of non-standard replacement fasteners, nuts, bolts, screws, studs and washers which are not connected with or which do not support any moving parts of the engine or its compulsorily retained accessories is permitted.
- (b) Gaskets are free and must be of approximate production thickness except for the cylinder head, carburettor to inlet manifold, and inlet manifold to cylinder head gaskets which must be of standard Ford manufacture for the engine.
- (c) Pump, fan and generator drive pulleys and their retention bolts, washers and belts are free.
- (d) The use of thread locking compounds is permitted.
- (e) Any process of cleaning may be used providing the surface finish on any component which must remain standard is not affected.

2.20 SUPERCHARGING:

- (a) Forced induction, eg, supercharging, is prohibited.

2.21 DISTRIBUTOR:

- (a) The distributor is defined as the component which triggers the LT current and distributes the HT ignition current. Distributors are free provided that they retain the original drive and location, the low tension ignition circuit is triggered from within the distributor body and the high tension ignition circuit is distributed from the distributor unit.
- (b) The ignition timing may be varied only by vacuum and/or mechanical means (weights & springs) from within the distributor body and a 90-degree firing angle shall be maintained.
- (c) It is prohibited to use any other method or component to trigger, distribute or time the ignition.
- (d) It is permitted to mount a simple indicating pointer to the engine to facilitate the timing of the distributor with respect to the crankshaft/flywheel.

2.22 ENGINE SCRUTINY:

Engines or components of engines may be removed and examined during the event, at the discretion of the chief scrutineer. Any irregularity will be referred to the stewards.

If, in the opinion of the scrutineers, there is a possibility of an irregularity in a component in any engine, then the scrutineers may decide that the engine be removed and sent for post-race inspection by the Formula Ford Association National Scrutineering Director.

The post-race inspection shall be in accordance with the FFA Post Race Engine Inspection Procedure.

If the National Scrutineering Director reports any irregularities these will be referred by the Formula Ford Association to Motorsport Australia for action.

FUEL SYSTEM

3.1 Fuel Pump:

Only the standard mechanical fuel pump or an after-market unit with similar dimensions and operation and fitted in the original location for the engine is permitted.

3.2 Fuel Pipes:

Fuel pipes are free.

3.3 Cooling:

Fuel cooling radiators are not permitted.

3.4 Fuel Tank:

Fuel tanks are free. Maximum capacity of fuel tank: 41 litres

3.5 Fuel Type:

Only Pump Fuel as per Schedule G

Only those Lead replacement additives as listed and permitted in Schedule G

Any fuel containing Ethanol (including E10, E85) is prohibited

TRANSMISSION

4.1 Gearbox:

- (a) The gearbox must contain no more than four forward gears and include an operable reverse gear, capable of being engaged by the driver whilst normally seated.
- (b) Gear selection mechanism must be mechanical in operation.
- (c) Electronic, sequential, hydraulic or pneumatic systems are prohibited.
- (d) Notwithstanding, cars which are the subject of a Certificate of Origin dated prior to 1 January 1988, and fitted with gearboxes incapable of carrying a reverse gear may continue to race without an operable reverse gear until further notice.

4.2 Ratios:

The ratios are free.

4.3 Drivetrain:

Rear-wheel drive only is permitted. Final drive ratio is free.

4.4 Differential:

Torque biasing, limited slip and locked differentials are prohibited. The use of non-ferrous material in differential components is prohibited, save that the thrust washer, Hewland Part No. HC8-214-5R, manufactured from plastic, is permitted.

CHASSIS

5.1 GENERAL:

From 1 January, 1999, all new Formula Ford chassis will be required to be constructed incorporating lateral protection structures as prescribed as follows:

- (a) A lateral protection structure is defined as continuous panels whose projection on a vertical plan parallel to the longitudinal axis of the car shall be at least 15cm high, shall extend on either side of the car, at a minimum distance of 55cm from the car's longitudinal centre line between at least the transverse planes passing through the fuel tank rear face and the frontal extremity of the minimum cockpit overall opening length, and at a minimum distance of 35cm from the car's longitudinal centre line between at least the transversal planes passing through the above extremity and the front rollover bar hoop.
- (b) These panels shall be made from a composite material of 30cm² minimum cross section with a honeycomb core in metal or Nomex® giving adequate resistance to compression.
- (c) The external skins shall be of aluminium alloy or plastic of a minimum thickness of 0.5mm or made up of another assembly of materials of equivalent efficiency. The panels must be securely attached to the bottom and at the upper extremity to the main structure of the car in such a manner as to ensure absorption of a lateral impact.
- (d) The radiators may play the role of protective panels or of transversal struts.
- (e) The periphery of the bodywork covering the lateral protection structure, when viewed from below, must be curved upwards with a minimum radius of 5cm, and a maximum radius of 7cm with the exception of air entry and exit openings into the lateral protection structure. The floor of the side pod must reflect the plan of the upper surface.

- (f) The floor is to be in the same plane as the undertray in both directions, ie transverse and longitudinal, subject to all points being within 2.54cm of any flat plane situated under the car (see 5.1 below).
- (g) Chassis with a Log Book issued prior to 30 June 1998 and constructed in accordance with the relevant regulations published in the 1997 and 1998 editions of the CAMS Manual may continue to race until further notice, subject to their continued compliance with these regulations.
- (h) The chassis must be of tubular steel construction with no stress-bearing panels except bulkheads and undertray; curvature of the undertray must not exceed 2.54cm.
- (i) Monocoque chassis construction is prohibited. Stress-bearing panels are defined as sheet metal affixed to the frame by welding, bonding or rivets or bolts or screws which have centres closer than 15.24cm.
- (j) Bodywork must not be used as stress-bearing panels.
- (k) Notwithstanding the provisions of Regulation 5.1 above, cars manufactured (and subject to a Certificate of Origin dated) prior to 1 January, 1985 and complying with the requirements published in the 1984 CAMS Manual may continue to race until further notice.
- (l) The use of stabilised/composite materials using carbon and/or Kevlar® reinforcement is prohibited.
- (m) No engine oil or water tubes are permitted within the cockpit
- (n) All cars manufactured on or after 1 January, 1987, must also comply with the following:
 - (i) the internal cross-sectional area of the cockpit from the soles of the driver's feet to behind their seat shall nowhere be less than 700 sq. cm. The minimum width must be 25cm over the whole length of the cockpit.
 - (ii) The only intrusion permitted into the cross-sectional area is the steering column;
 - (A) the driver's feet (in normal position, pedals not depressed) must be located behind a line drawn through the front wheel axis.
- (o) No part of the car, except for tyres, may be closer to the ground than 40mm. This measurement will be taken with the driver seated at the steering wheel, the car in race trim and with the wheels pointed straight ahead.

WHEELS AND TYRES

6.1 Wheels must;

- (a) have a diameter of 13" and a maximum rim width of 5.5".
- (b) They must be of either steel or alloy construction.
- (c) Steel wheels must be of conventional construction utilising welding and/or riveting to attach the steel rim to the centre, which must also be of steel.
- (d) Alloy wheels must be manufactured entirely from a single casting of aluminium alloy (not less than 90% aluminium content) and be mass produced items.
- (e) Steel reinforcements around the mounting holes are permitted.

For safety reasons, it is strongly recommended that weekly checks are carried out and that wheels are renewed at least once every year.

6.2 Tyres:

The make, type, specification and dimensions of the tyres permissible for use in Formula Ford competition shall be advised from time to time. The permissible tyres are:

- (a) YOKOHAMA: A048 soft compound
 - (i) FRONT - 185/60HR13 A048S article # K9729
 - (ii) REAR - 205/60HR13 A048S article # K9730
- (b) At the commencement of any official timed practice, qualifying session or race, the minimum depth of tread measured alongside the tread wear indicator must be at least 1.5mm. Isolated flat spots may not render a tyre ineligible unless deemed unsafe for competition. The original tread pattern must always remain visible on any tyre that is fitted to any automobile.
- (c) The use of any device to artificially heat the tyres is prohibited.

- (d) Protective tyre covers may be used in the paddock area. Their use is prohibited in the assembly, impound and scrutiny areas and they must not be re-fitted until after all post-session checks are completed.
- (e) Tyres must only be inflated with air.
- (f) With the exception of wear resulting from friction with the track surface, all tyres must remain unmodified.

STEERING GEAR

7.1 Steering System:

The complete steering system is free.

BRAKES

8.1 Braking System:

The complete braking system is free, save that:

- (a) it must be a dual system;
- (b) only calipers and/or caliper pistons made predominantly from ferrous material are permitted;
- (c) only brake discs made predominantly from ferrous material are permitted;
- (d) cross-drilling of brake discs is prohibited.

SUSPENSION AND RUNNING GEAR

9.1 Suspension System:

All parts of the suspension system must be of steel or ferrous material, with the exception of bellcranks, tracking or alignment arms, hubs, hub adaptors, hub carriers, bearings and bushes, spring caps, abutment nuts and anti-roll bar links.

- (a) Active suspensions are prohibited, as is any system which allows control of the flexibility of the suspension springs, shock absorption and trim height whilst the car is moving.
- (b) The use of titanium is prohibited.
- (c) Shock absorbers are free, save that vehicles cannot be fitted with more than four, ie, no more than two at the front and rear.
- (d) Interconnection of fluid between units and mechanical interconnection between front and rear units is not permitted.

ELECTRICAL EQUIPMENT

10.1 The following applies to all Electrical Equipment:

- (a) Generator is optional.
- (b) The use of a rev-limiter is optional. If used, a rev-limiter must only have three wires, one of which must be an earth.
- (c) A starter motor, capable of starting the engine at the start of and during an event, must be fitted.

BODY

11.1 Aerodynamic Devices:

Any device designed to aerodynamically augment the downthrust on the vehicle is prohibited. These devices specifically include;

- (a) aerofoils,
- (b) venturi tunnels,
- (c) skirts,

- (d) nose fins
- (e) spoilers of any kind.
- (f) Integration of aerofoils and spoilers by design or the mismatching of bodywork and/or chassis panels and members is also prohibited.

11.2 Dimensions:

For Table of Single-Seater Dimensions refer to **Appendix A**.

- (a) The upper rear bodywork (located above the wheel centreline) is permitted to extend rearwards for a maximum of 375mm from a line drawn through the rear wheel axis.
- (b) The maximum height at any part wider than 110cm ahead of the front wheels is not to exceed the front wheel rim height.

11.3 Bodywork:

- (a) The shape of the bodywork behind a vertical line drawn from the highest point of the roll-over bar must not include any reflex curves or flat surfaces which are capable of augmenting downthrust.
- (b) The lower rear bodywork (located below the wheel centreline) is only permitted alongside and beneath the engine and may only extend from behind the cockpit to a line drawn through the rear wheel axis.
- (c) The incorporation of suspension or other fairings in this bodywork is prohibited.
- (d) It is not permitted to construct any suspension member in the form of an aerofoil or to incorporate a spoiler in the construction of any suspension member.
- (e) The use of suspension fairings separate from this bodywork is prohibited.
- (f) The use of composite materials using carbon fibre reinforcement is prohibited

11.4 Roll over Protection:

A roll bar is required to be fitted behind the driver's head. It must be configured;

- (a) so that the top of the driver's helmet is 50mm vertically below the top of the roll bar, and at least below a line drawn from the top of the roll hoop to the top of the front bulkhead (see points 1 and 2 on diagram 1.1 Type 1 accompanying the table of dimensions).
- (b) The roll bar must be either:
 - (i) made from 38mm x 2.5mm cold drawn seamless tubing, and comply with the configuration shown as Type 1; or
 - (ii) an alternative design capable of withstanding a vertical load of 36.4 kN and a load of 26.7 kN applied at the top of the roll bar and directed horizontally to the rear. Such a design must be certified by Motorsport Australia, or another ASN.



Type 1: Solo Roll Bar

11.5 Seat Belts:

Seat belts must be fitted in accordance with the requirements of Schedule I (refer to Technical Appendix).

11.6 Nose Cone:

Nose boxes/cones manufactured in ferrous materials (eg, steel) are prohibited.

WEIGHT

12.1 Minimum Weight:

The minimum racing weights at any time including the driver with helmet and wearing all apparel (eg, as at the end of a race or practice) shall be 510kg as recorded on the scales at the circuit on the day of the event. Any ballast which is carried must be securely fixed (eg, welded, riveted or bolted) and located in a position able to be readily checked.

ENGINE SEALING

13.1 Scrutineering:

All engines must have provision for scrutineers' wire seals – 2mm (5/64") holes pre-drilled in readily accessible locations on installed engines must be available if requested by the scrutineers. The following are required:

- (a) Sump - two holes through the cylinder block/sump joint flange, one either side of the engine.
- (b) Timing Cover - at least two retaining screw heads must be cross-drilled.
- (c) Rocker Cover - at least two retaining screw heads must be cross-drilled.
- (d) Carburettor - at least two of the retaining nuts must be cross-drilled.
- (e) Distributor - no special requirement.
- (f) Bell Housing - at least two of the bolts fastening the housing to the engine must be cross-drilled to provide sealing of the clutch/flywheel assembly; alternatively entrants may provide for sealing of the clutch and flywheel by cross-drilling at least two of the clutch cover retaining bolts.
- (g) Inlet Manifold - the heads of at least two of the retaining bolts must be cross-drilled.
- (h) Cylinder Head - at least the two rear exposed cylinder head retaining bolts must be drilled.

MISCELLANEOUS

14.1 Engine Components:

Engine components not covered by these Regulations must remain standard and unmodified. The requirement for the use of standard parts is deemed to mean the part, as defined by the part number, prescribed by the Ford Motor Co. spare parts listing for the appropriate engine.

Unless otherwise specified herein, all parts shall be "standard" parts and further, unless specifically authorised they shall not be altered in any way; and they shall be assembled and fitted in the manner intended by the Ford Motor Co.

14.2 Composites:

The use of titanium, high strength composites (e.g. carbon or Kevlar) and similar material is prohibited, save where specifically authorised in these Regulations.

14.3 Data Recording:

Each car may only be fitted with one data recording unit and unless otherwise specified one of each of the following sensors:

- (a) Engine Sensors:
 - (i) Engine RPM;
 - (ii) Throttle Position;
 - (iii) Coolant Temperature;
 - (iv) Oil Pressure;
 - (v) Oil Temperature;
 - (vi) Lambda.
- (b) General Sensors:
 - (i) Front Wheel Speed (x2);
 - (ii) Steering Angle;

- (iii) G-Force Longitudinal;
- (iv) G-Force
- (v) Lateral;
- (vi) G-Force Vertical;
- (vii) Suspension Position (x4);
- (viii) Brake Line Pressure - Front;
- (ix) Brake Line Pressure - Rear;
- (x) Battery Voltage;
- (xi) Oil Temperature;
- (xii) Cockpit
- (xiii) Temperature;
- (xiv) Beacon Input;
- (xv) Global Positioning Sensor (GPS)

- (c) Random data sampling may be undertaken by the Technical Commissioner.
- (d) Telemetry devices are prohibited.
- (e) The fitment of an electronic timing device as required by the circuit timing systems is permitted.
- (f) Timing transmitters must be fitted, in accordance with the manufacturer's instructions, at a position no less than 1.6m behind the point of the nose of the car, unless otherwise directed by event officials.
- (g) Fitment of video recording devices may be fitted subject to approval by the scrutineers.

14.4 Communication Systems

Communication systems, designed to provide audible communication only between the driver and pit during competition, are permitted. Refer to the *Motorsport Australia* Circuit Race Standing Regulations.

The communication system shall not be utilised for any other purpose.

14.5 COMPETITION NUMBERS AND BACKGROUNDS:

All competitors (save historic and older cars as provided below) in all competitions shall use competition numbers and backgrounds of common design and size.

The backgrounds shall be white, rectangular and defined by a 3mm black border. The background including border shall measure 190mm x 230mm. The numbers shall be 165mm high, black, of the typestyle known as **ZURICH BOLD** (example shown here):

1 2 3 4 5 6 7 8 9 0

Each car must display its competition number in three locations: on the nose of the car, in a location visible to a person standing directly in front of the car at a distance of at least 10m; and one on each side of the car at a position between the rear of the driver and the leading edge of the rear wheel, at a minimum height of 300mm above the bottom of the car and above any sidepods.

Competitors in historic and older cars constructed without engine covers are required to display the side backgrounds and numbers on the side of the car in the most prominent position possible.

Appendix A

Singe Seater Dimensions

Table of Single Seater dimensions

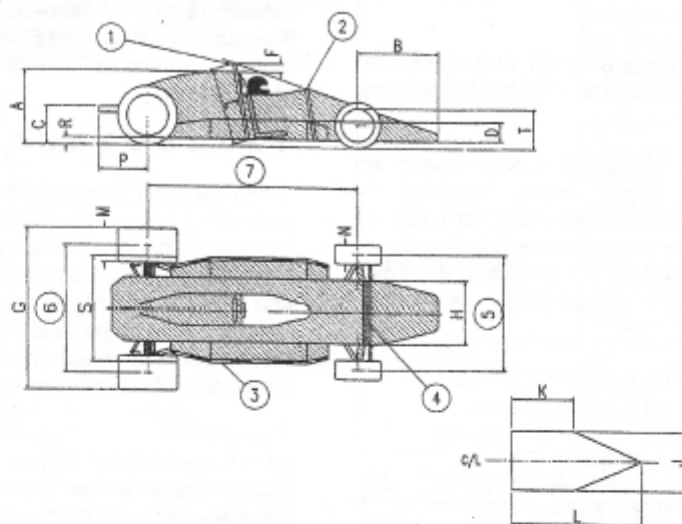

- | | |
|---------------------------------|----------------------------------|
| 1. Safety roll over bar | 2. Substantial support structure |
| 3. Lateral Protection structure | 4. Substantial structure |
| 5. Front track | 6. Rear track |
| 7. Wheelbase | |

Notes

- Maximum height is measured with the driver aboard.
- Maximum height excludes safety roll-over bar on which there is no maximum height.

Single Seater dimensions – refer to drawing

(A)	Maximum body height measured from ground	900
(B)	Maximum front overhang from front wheel axis	1000
(C)	Exhaust height measured from the ground	600 Max
(D)	Minimum height of Lateral Protection Structure	150
(E)	Minimum safety roll-over bar length in line with drivers spine	920
(F)	Minimum allowed helmet clearance	50
(G)	Maximum width	1850
(H)	Maximum body width behind front wheels	950
(J)	Minimum cockpit opening	450
(K)	Minimum cockpit parallel opening length	300
(L)	Minimum cockpit overall opening length	600
(M)	Maximum rear wheel width	5.5 inch
(N)	Maximum front wheel width	5.5 inch
(P)	Maximum exhaust length from rear wheel axis	600
(R)	Minimum ground clearance	40
(S)	Maximum width including lateral protection structure	1300
(T)	The maximum height of any part wider than 1100mm ahead of the front wheels is not to exceed the front rim height	

Minimum wheelbase	2000
Minimum track	1200
Wheel diameters	13 inch

ALL dimensions in **mm** unless specifically stated