

Group 3E RECOGNITION DOCUMENT

A) Vehicle seen from 3/4 front

B) Vehicle seen from 3/4 rear



1. GENERAL

101. Manufacturer

MITSUBISHI MOTORS CORPORATION

102. Commercial name(s) - Model and type

LANCER EVO IX (CT9A) GSR

103. Engine capacity

1997 cm³ Corrected engine capacity 1997 x 1.7 = 3394.9 cm³

104. Type of car construction

a) Type

<input type="checkbox"/> separate chassis	<input checked="" type="checkbox"/> monocoque
---	---

b) Material of chassis / bodyshell

STEEL

106. Number of seats

5

2. DIMENSIONS, WEIGHT

Minimum Racing Weight

1450 kg

202. Overall length

4490 mm ± 1 %

203. Maximum overall width

1770 mm ± 1 % Where measured AT FRONT AXLE

204. Width of bodywork

a) At front axle **1770 mm ± 1 %**

b) At rear axle **1770 mm ± 1 %**

206. Wheelbase **2625 mm ± 1 %**

207. Maximum track

a) Front **930 mm**

b) Rear **935 mm**

3. ENGINE (In case of rotary engine, see Art. 335 on additional form)

301. Location and position of the engine **FRONT LATERAL VERTICAL**

302. Number of mounts **3**

Engine in its compartment



304. Supercharging yes no

Maximum manifold pressure **1.21 BAR**

Type and number of compressors **EXHAUST TURBOCHARGER SINGLE**

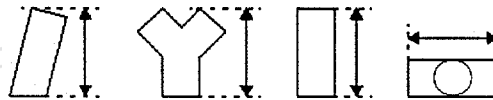

305. Number and layout of cylinders **4 INLINE**

312. Cylinder block material **CAST IRON**

310. Maximum compression ratio **8.8: 1**

313. Sleeves a) yes no b) Material

c) wet dry

314. Bore **85.05**+0/- 0.1 mm

316. Stroke **88.1**+0/- 0.1 mm

321. Cylinderhead a) Number **1** b) Material **ALLUMINIUM ALLOY**

324. Fuel feed by injection : a) Make **DENSO, WESCO** b) Model **ECI MULTI**

f) Position of injectors
f1) Manifold Cylinderhead

325. Camshaft a) Number **2** b) Location **DOHC**

c) Drive system **NOTCHED BELT** f) Type of valve operation **ROCKER ARM**

327. Intake a) Material of manifold **ALUMINIUM ALLOY**

b) Number of manifold elements **1** c) Number of valves per cylinder **2**



328. Exhaust

- a) Material of manifold **CAST IRON**
- b) Number of manifold elements **1**
- c) External diameter of exhaust pipe between manifold and first silencer **60.5 mm ± 5%**
- d) Number of valves per cylinder **2**

330. Ignition system

- a) Type **ELECTRONIC MITSUBISHI**
- b) Number of plugs per cylinder **1**
- c) Number of distributors **0**
- d) Number of coils **2**

331. Cooling system

Capacity **6.0 l**

332. Cooling fan

- a) Number **1**
- b) Diameter of the fan **320/320 mm**
- c) Material of the fan **PLASTIC**
- d) Number of blades **9/5**
- e) Type of drive **ELECTRIC**
- f) Automatic cut in

<input checked="" type="checkbox"/> yes	<input type="checkbox"/> no
---	-----------------------------

333. Lubrication system

- a) Type **WET SUMP**
- c) Total capacity **5.5 L**
- e) Location of the cooler(s) **FRONT UNDER RHS HEAD LAMP**
- f) Type of the cooler(s) **RADIATOR**

4. FUEL CIRCUIT

401. Fuel tank

- a) Number **1**
- b) Location **UNDER BODY, MID MOUNT**
- d) Total capacity **57 L**
- e) Filler hole locations **LEFT REAR FENDER**

402. Fuel pump(s)

- a)

<input checked="" type="checkbox"/> Elelectrical	<input type="checkbox"/> Mechanical
--	-------------------------------------
- b) Number **1**
- d) Location **IN TANK**

5. ELECTRICAL EQUIPMENT

502. Alternator

- a) Number **1**
- b) Type **ALTERNATOR**
- c) Drive system **V-BELT**
- d) Nominal power **1.080 Watts**

503. Retractable headlights

- a)

<input type="checkbox"/> yes	<input checked="" type="checkbox"/> no
------------------------------	--
- b) Control system **XXXX**

6. POWER TRAIN

601. Driven wheels

- front

<input checked="" type="checkbox"/> yes	<input type="checkbox"/> no
---	-----------------------------
- rear

<input checked="" type="checkbox"/> yes	<input type="checkbox"/> no
---	-----------------------------

602. Clutch

- a) Type **SINGLE DRY PLATE**
- b) Control system **HYDRAULIC**



603. Gearbox

- a) Location **FRONT**
- b) Make **MITSUBISHI**
- c) Type and location of control **6 MECHANICAL ON FLOOR**
- e) Ratios

	Number of teeth	Ratio	Constant Mesh	Synchro
1	_____	2.909:1	_____	_____
2	_____	1.944:1	_____	_____
3	_____	1.434:1	_____	_____
4	_____	1.100:1	_____	_____
5	_____	0.868:1	_____	_____
6	_____	0.693:1	_____	_____
R	_____	2.707:1	_____	_____
Constant	_____	_____	_____	_____

f) Gear change gate

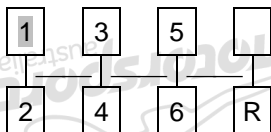

g) Type of lubrication

604. Transfer box / Centre differential

- a) Ratios **0.302**
- c) Control system of transfer box **XXXX**
- d) Type of central differential **HYPOID & BEVEL GEAR**

605. Final drive

a) Type of final drive

	Front	Rear
a) Type of final drive	MECHANICAL HELICAL GEAR	MECHANICAL ACD & AYC
b) Ratio	4.583	
f) Oil Cooler	<input type="checkbox"/> yes	<input checked="" type="checkbox"/> no
g) Cooler Type	N/A	N/A

606. Shafts

- a) Type of longitudinal shafts **3 UNIVERSAL JOINTS AND CROSS GROOVE JOINT**
- b) Material of longitudinal shafts **STEEL**
- c) Type of transversal half-shafts **BALL JOINT + TRIPOD JOINT**
- d) Material of transversal half-shafts **STEEL**



7. SUSPENSION

701. General

	Front	Rear
a) Type of suspension	<u>INDEPENDENT MCPHERSON</u>	<u>INDEPENDENT MULTILINK WITH DOUBLE WISHBONE</u>
	<input checked="" type="checkbox"/> yes <input type="checkbox"/> no	<input checked="" type="checkbox"/> yes <input type="checkbox"/> no
a) Material	<u>STEEL</u>	<u>STEEL</u>
703. Leaf springs	<input type="checkbox"/> yes <input checked="" type="checkbox"/> no	<input type="checkbox"/> yes <input checked="" type="checkbox"/> no
704. Torsion bars	<input type="checkbox"/> yes	<input checked="" type="checkbox"/> no
a) Material	<u>XXXX</u>	<u>XXXX</u>

705. Other type of suspension

See description on additional form

706. Stabiliser

	Front	Rear
b) Effective diameter	<u>24</u> +/- 0.2 mm	<u>22</u> +/- 0.2mm
c) Material	<u>STEEL</u>	<u>STEEL</u>

707. Suspension Dampers

	Front	Rear
a) Number per wheel	<u>1</u>	<u>1</u>
b) Type	<u>TELESCOPIC</u>	<u>TELESCOPIC</u>
c) Principle of operation	<u>HYDRAULIC</u>	<u>HYDRAULIC</u>

8. WHEELS

801. Wheels

	Front	Rear
a) Diameter	<u>17"</u>	<u>17"</u>
b) Width	<u>8"</u>	<u>8"</u>
c) Offset	<u>+38</u> mm	<u>+38</u> mm

803. Brakes

- a) Braking system **HYDRUALIC WITH ABS**
- b) Number of master cylinders **1**
- c) Servo-brakes yes no

c1) Make and type

BOSCH BRAKING SYSTEM, VACUUM



	Front	Rear
e) Number of cylinders per wheel	<u>4</u>	<u>2</u>
f) Drum brakes		
f1) Internal diameter	<u>XXXX</u> ± 1.5 mm	<u>XXXX</u> ± 1.5 mm
f2) Number of linings per wheel	<u>XXXX</u>	<u>XXXX</u>
g) Disc brakes		
g1) Number of pads per wheel	<u>2</u>	<u>2</u>
g2) Number of calipers per wheel	<u>1</u>	<u>1</u>
g3) Caliper material	<u>STEEL</u>	<u>STEEL</u>
g4) Thickness of new disc	<u>32</u> ± 1 mm	<u>22</u> ± 1 mm
g5) External diameter of the disc	<u>320</u> ± 1.5 mm	<u>300</u> ± 1.5 mm
g9) Ventilated discs	<input checked="" type="checkbox"/> yes <input type="checkbox"/> no	<input checked="" type="checkbox"/> yes <input type="checkbox"/> no

h) Parking brake

h1) Control system

MECHANICAL

h2) Location of lever

BETWEEN FRONT SEATS

<input type="checkbox"/> Front	<input checked="" type="checkbox"/> Rear
--------------------------------	--

804. Steering

a) Type

Front		Rear	
<u>RACK & PINION</u>		<u>XXXX</u>	
<input checked="" type="checkbox"/> yes	<input type="checkbox"/> no	<input type="checkbox"/> yes	<input checked="" type="checkbox"/> no
<u>HYDRAULIC</u>		<u>XXXX</u>	

b) Servo-assistance

Type of Assistance

9. BODYWORK

901. Interior

a) Ventilation

<input checked="" type="checkbox"/> yes	<input type="checkbox"/> no
<input checked="" type="checkbox"/> yes	<input type="checkbox"/> no

c) Air Conditioning

b) Heating

<input checked="" type="checkbox"/> yes	<input type="checkbox"/> no
---	-----------------------------

f) Optional sun roof

<input type="checkbox"/> yes	<input checked="" type="checkbox"/> no
------------------------------	--

f1) Type

XXXX

f2) Control system

XXXX

g) Opening system for side windows

Front	Rear
<u>ELECTRIC POWER</u>	<u>ELECTRIC POWER</u>



X) Dashboard

Y) Sunroof



902. Exterior

a) Number of doors **4**

b) Tailgate yes no

Front	Rear
<u>STEEL</u>	<u>STEEL</u>

c) Door material

d) Front bonnet material

ALLOY

e) Rear bootlid / tailgate material

STEEL

f) Bodywork material

STEEL/ALLOY FENDERS

h) Rear window material

SAFETY GLASS

i) Rear quarter window material

SAFETY GLASS

k) Side window material

Front	Rear
<u>GLASS</u>	<u>GLASS</u>
<u>PLASTIC</u>	<u>PLASTIC</u>

l) Material of bumper

n) Exterior Rear wiper

<input type="checkbox"/> yes	<input checked="" type="checkbox"/> no
------------------------------	--

XIII) NON METALLIC PARTS OF THE BODY

Number	Part	Material
1	Face, Bumper, Front	Polypropylene
2	Lamp, Head	Polycarbonate
3	Air Dam, Side	Polypropylene
4	Mirror, Door	Acrylonitrile Butadiene Styrene
5-a	Spoiler, Rear Centre	Carbon
5-b	Spoiler, Rear Side	Acrylonitrile Butadiene Styrene
6	Antenna, Centre Roof	Thermoplastic Elastomers
7	Face, Bumpker Rear	Polypropylene
8	Lamp, Rear Combination	Polymethyl Methacrylate
9	Handle, Door Outside	Polyethylene Terephthalate
10	Mark, 3 Diamond	Acrylonitrile Butadiene Styrene
11	Lamp, Side Turn Signal	Polymethyl Methacrylate
12	Deck, Front Garnish	Polypropylene
13	Moulding	Polyvinyl Chloride Plastic

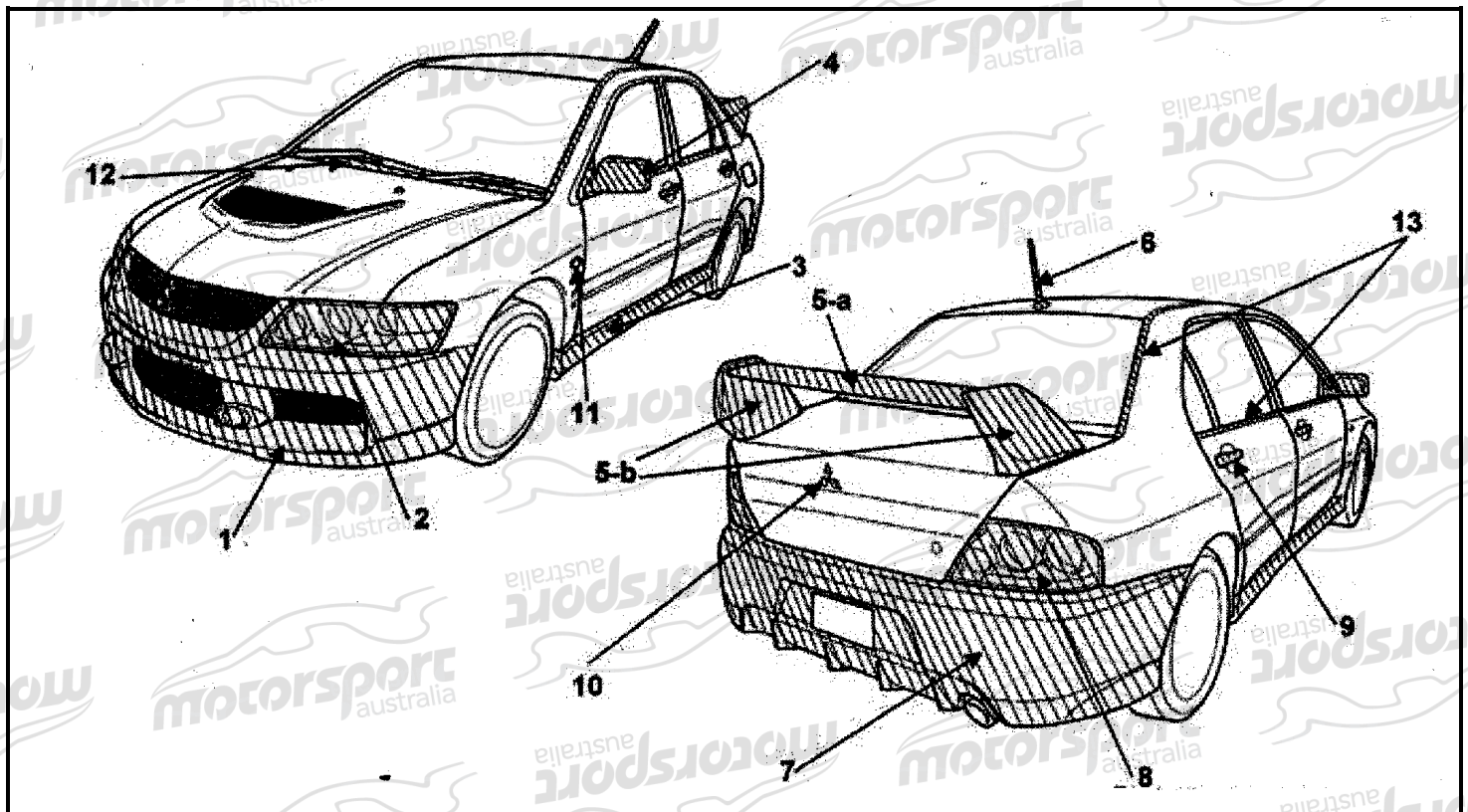

COMPLEMENTARY INFORMATION

DIFFERENTIAL MOUNT

The front of differential carrier is supported with the differential support member via the differential mount bracket. The rear is supported with the differential mount bracket and the differential support arm.

CONSTRUCTION DIAGRAM

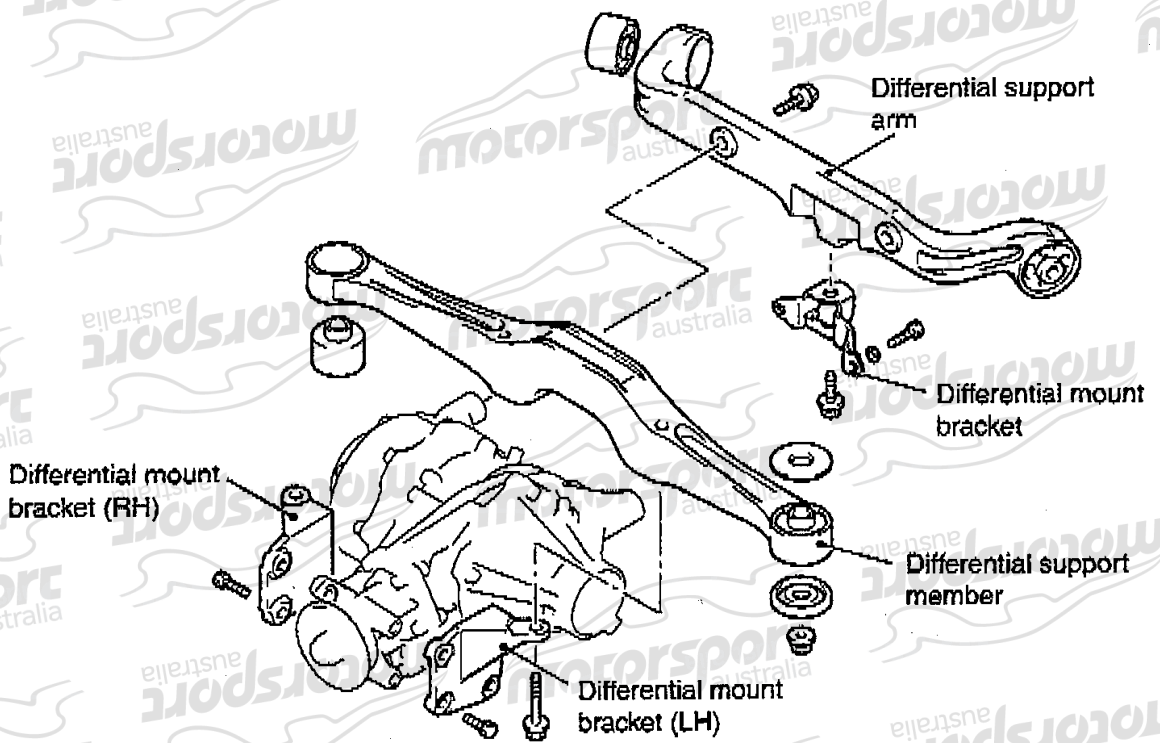

Gear Ratios: First	2.909
Second	1.944
Third	1.434
Fourth	1.100
Fifth	0.868
Sixth	0.693
Reverse	2.707
Final Drive	4.583