

OFF ROAD APPENDIX

OFF ROAD SPECIFIC REQUIREMENTS

TECHNICAL REGULATIONS

Modified Article	Date of Application	Date of Publication
11.7(a)	01/01/2025	01/01/2025
11.9(d)	01/01/2025	01/01/2025

A capitalised and italicised word in this document is defined in the FIA International Sporting Code (Code) or the National Competition Rules (NCR), including their Appendices.

Any HEADING is for reference only and has no regulatory effect.

NOTE: References in the text to “GR” refer to “General Requirements”, to be found in the Off Road Appendix in the *Motorsport Australia Manual*.

Buggy Classes

1. GENERAL

- (a) Buggies are generally *Automobiles* of tube frame construction designed for the purpose of competing in Off Road events. All buggies must comply with GR 2-30, noting the requirements of GR 9 Chassis/Frame and, if required by regulations for a specific event, one or more of GR 31.
- (b) Where the class rules permit a single seat, the driver’s seat may be either centrally located or to the left or right of centre. Any such vehicle may only compete in that configuration if an unused seat and harness is removed.
- (c) Buggies will be eligible to be entered in only one buggy class, whether or not they comply with the regulations for more than one class, unless specifically outlined in the relevant sporting or supplementary regulations.

2. PRO BUGGY

2.1 Buggies with applicable engine capacities.

(a) ELIGIBILITY/DEFINITION

A one or two-seat, two-wheel drive *Automobile*, as defined in GR 1.

Engine capacity must not exceed:

- (i) 7000cc (+1%) for naturally aspirated petrol engines;
- (ii) 6000cc (+1%) for supercharged petrol engines inclusive of any supercharging/rotary multiplication factors; or
- (iii) 7200cc (+1%) for diesel engines, inclusive of any supercharging, multiplication factors.

3. PROLITE BUGGY

3.1 Buggies with engines up to 3500cc, naturally-aspirated.

(a) ELIGIBILITY/DEFINITION

A one or two-seat, two-wheel drive *Automobile*, as defined in GR 1.

Engine capacity must be up to 3500cc (+1%), inclusive of any rotary and/or diesel correction factors. All engines must be naturally aspirated (i.e., no turbo or supercharging device is permitted).

4. SPORTSLITE

4.1 Buggy or Extreme 2WD bodied *Automobile*.

(a) ELIGIBILITY DEFINITION

A one or two seat, two-wheel drive *Automobile*, either buggy or Extreme 2WD, as defined in GR1 with a maximum engine capacity of:

- (i) 2500cc for naturally aspirated petrol engines; or
- (ii) 4 cylinder 1600cc (swept volume) forced induction petrol engines.

NOTE: Fuel permitted is in accordance with GR27.

(b) ENGINE RESTRICTION

- (i) Each forced induction engine must be fitted with an inlet air restrictor with a maximum internal diameter of 32mm, in accordance to Attachment 2: Sportslite Restrictor. All the intake air for the engine must pass through this restrictor.

NOTE: *Motorsport Australia* may apply other engine restrictions. Any application by *Motorsport Australia* of further restrictions will be undertaken following review and consultation.

5. SUPER 1650 BUGGY

5.1 Buggies with engines not exceeding 1650cc.

(a) ELIGIBILITY/DEFINITION

A two-seat, two-wheel drive *Automobile*, as defined in GR 1.

Engine capacity must not exceed 1650cc, inclusive of any turbo/supercharging, rotary and/or diesel correction factors.

6. SPORTSMAN BUGGY

6.1 Buggies with engines not exceeding 1330cc.

(a) ELIGIBILITY/DEFINITION

A two-seat, two-wheel drive *Automobile*, as defined in GR 1.

Engine capacity must not exceed 1330cc, inclusive of any turbo/supercharging, rotary and/or diesel correction factors.

Two-Wheel Drive (2WD)

2WD cars will be eligible to be entered in only one 2WD class, whether or not they comply with the regulations for more than one class, unless specifically outlined in the relevant sporting or supplementary regulations.

7. PERFORMANCE 2WD

Modified 2WD

7.1 ELIGIBILITY/DEFINITION

- (a) A two-wheel drive *Automobile* as defined in GR 1 with provision for at least two crew members which is derived from a Series Production type being either:

- (i) an *Automobile* recognised by the FIA in Group A or B, and/or recognised by *Motorsport Australia*; or
- (ii) a commercially-manufactured utility-type truck, pick-up or station wagon up to 1.5 tonnes rated load capacity, recognised by *Motorsport Australia* and which complies with GR 2-24 and 25-30 and, if required for a specific event, one or more of GR 31.

NOTE: Special attention should be paid to GR 9 (chassis), GR 12(b) (head restraints), GR 16 (steering) and GR 18 (safety cage structure).

- (b) All modifications are allowed except for those prohibited in the following regulations.

7.2 COACHWORK

- (a) The original silhouette of the coachwork of the vehicle, when viewed from the side, must be retained except as specifically permitted below:
- (i) the bodyshell (see *Motorsport Australia Manual* – Technical Appendix - Definitions Technical) must be unchanged in material save that external non-stress bearing panels (e.g., the mudguards, bonnet, boot lid and tailgate/s) may be replaced by panels of free construction;
 - (ii) the tailgate may be removed;
 - (iii) It is permitted to remove material from the engine cover to facilitate the fitment of larger and/or multiple air cleaners, provided always that the shape of the panel is clearly identifiable. This freedom does not allow the addition of any material to the exterior surface of the panel, the bumper bars and external decoration may be removed. The body must have a neat and professional appearance;
 - (iv) the coachwork beneath the bumper bar mountings may be removed between those mountings and the centre of the corresponding wheel;
 - (v) a bull bar/brush guard not exceeding the width (at the front) of the bodywork may be fitted;
 - (vi) the radiator grille must remain unchanged in shape and must remain in its original location;
 - (vii) the fitting of equipment and/or ancillary mechanical components in the cargo compartments of utility/pick-up-type vehicles is permitted, provided that this does not alter the silhouette outside the area bounded by the rear of the cabin, the top of the side panels of the rear cargo area, and a straight line drawn from the top of the tailgate to the rear of the roof save for the fuel tank/s or spare wheel;
 - (viii) the maximum permitted variation of the wheelbase from the manufacturer's specification is plus or minus 3%;
 - (ix) two independent methods of retaining the bonnet are required; and
 - (x) one or more roof vents may be fitted, but they must be in the forward one-third of the roof, with their opens side facing forward, and their vertical opening not greater than 10cm.
- (b) Complete wheels (see *Motorsport Australia Manual* – Technical Appendix - Definitions Technical) must be covered by mudguards, or flares firmly attached to the mudguard, for at least one third of the circumference of the wheel (over the full width of the assembly).
- (c) Each windscreens may be either removed, or replaced with one of the following:
- (i) an aero type windscreen (i.e., a windscreen that is fitted to the lower half of the original windscreen opening) of polycarbonate (e.g., Lexan) or other suitable rigid material; or
 - (ii) shatterproof or laminated glass windscreen.
- (d) The front doors are required to comply with the following:
- (i) the original front door frames must be retained, except that the portion of the door above the lower level of the window aperture may be removed;
 - (ii) the original front door hinges and catches are required to be retained;
 - (iii) any internal anti-theft locks are required to be rendered inoperative;
 - (iv) the door trim, if removed, is required to be replaced by flush-fitting rigid material, and
 - (v) if the door is modified from the original, other than as provided for in Article 7.2(d) above, door bars are required to be incorporated into the safety cage.
- (e) The use of chassis/cab vehicles without rear bodywork, and of tray-top vehicles, is prohibited.

7.3 CHASSIS

- (a) The original chassis and/or monocoque, including any sub-frames, must be retained in its original location; and must remain unchanged in dimensions, plan view and silhouette.
- (b) Engine and transmission mounts and cross-members may be removed, relocated or refurbished.
- (c) Any brackets and mounts rendered surplus by authorised modifications may be removed.
- (d) It is permissible to remove the minimum amount of material necessary to allow the fitment of approved wheels, tyres and suspension permitted under these regulations, however this freedom does not extend to steering (e.g., tie rods).

7.4 SAFETY CAGE STRUCTURE

- (a) A safety cage structure, as outlined in GR 18 must be fitted to all vehicles.
- (b) A fibreglass- or plastic-bodied vehicle must incorporate a roof plate as specified in GR 13 for open cars.

7.5 ENGINE/TRANSMISSION

- (a) The type and location of engine is free provided that it is located in the same general area as envisaged by the manufacturer of the body.

Engine capacity must not exceed:

- (i) 7000cc (+1%) for naturally aspirated petrol engines;
 - (ii) 6000cc (+1%) for supercharged petrol engines inclusive of any supercharging/rotary multiplication factors; or
 - (iii) 7200cc (+1%) for diesel engines, inclusive of any supercharging multiplication factors.
- (b) Engines mounted in front or rear may intrude into the space originally intended for passengers, save that no part of the cylinder block may extend across a line drawn at right angles to the longitudinal axis of the car, at a point halfway between the front and rear wheel hub centres.
 - (c) The original engine/gearbox/final drive configuration, in relation to the body, must be retained.
 - (d) Engine covers inside the car must be of the same material as the firewall, and may be attached to the firewall by any method deemed safe by the event chief scrutineer.
 - (e) Drive shafts must be contained in such a way that they cannot enter the cabin area in case of breakage.

7.6 ELECTRICAL

- (a) In addition to GR 24, 25 and 26, tail lamps and stop lamps must be fitted and operational and must be as near to original as possible. A dust lamp must be fitted.
- (b) The original headlamp position/s must be retained, and the lamps must be operable.

7.7 FUEL TANK

If fitted in the cockpit the fuel tank must be separated from the occupants by a separate fire and liquid proof bulkhead.

7.8 BRAKING SYSTEM

Each vehicle must be fitted with a dual circuit braking system arranged so that in the event of a leakage at any point in the system, the pedal must still control two wheels on the same axle.

8. EXTREME 2WD

Highly-modified 2WD including Baja.

8.1 ELIGIBILITY/DEFINITION

- (a) A two-wheel drive *Automobile*, as defined in GR 1, and which may be fitted with either one or two seats. The front and rear of the body must substantially resemble that of the production vehicle from which it is derived, or that of a VW Baja, the body of which must be a Type One Volkswagen hardtop sedan which may be modified as specified hereunder. Vehicles must comply with GR 2-30 and, if required by regulations for a specific event, GR 31.
- (b) All modifications are allowed, save for the restrictions specified hereunder.

8.2 COACHWORK/CHASSIS

- (a) The body must be derived from a production *Automobile* and substantially resemble it.

8.3 SAFETY CAGE STRUCTURE

A safety cage structure, as specified in GR 18 must be fitted or alternatively the vehicle must incorporate a frame which complies with GR 9.

8.4 ENGINE

- (a) The engine is free, except for engine capacity.

Engine capacity must not exceed:

- (i) 7000cc (+1%) for naturally aspirated petrol engines;
 - (ii) 6000cc (+1%) for supercharged petrol engines inclusive of any supercharging/rotary multiplication factors; or
 - (iii) 7200cc (+1%) for diesel engines, inclusive of any supercharging multiplication factors.
- (b) Modifications to the engine are free.
- (c) The location of the engine is free, save that no part of the cylinder block may extend across a line drawn at right angles to the longitudinal axis of the car, at a point halfway between the front and rear wheel hub centres.

8.5 TRANSMISSION

- (a) Cars subject of a log book issued from 1 January 2011:
- (i) A transaxle type transmission may only be used where the body of the vehicle is derived from one originally fitted with a transmission of this type. The gearbox, differential and axle housings are otherwise free.
- (b) Cars subject of a log book issued prior to 1 January 2011:
- (i) A car which does not comply with (a) but which has a competition history in Extreme 2WD prior to 1 January 2011 and continues to comply with the 2010 Extreme 2WD regulations may continue to be used in Extreme 2WD competition subject to approval by *Motorsport Australia*. Applications must be addressed to the Australian Off Road Commission (AORCom).

8.6 ELECTRICAL

The requirements of GR 24-26 must be complied with.

Four-Wheel Drive (4WD)

9. PRODUCTION 4WD

Production 4WD with engine not exceeding:

- (i) 7000cc (+1%) for naturally aspirated petrol engines;
- (ii) 6000cc (+1%) for supercharged petrol engines inclusive of any supercharging/rotary multiplication factors; or
- (iii) 7200cc (+1%) for diesel engines, inclusive of any supercharging multiplication factors.

9.2 PREAMBLE

- (a) All modifications are forbidden unless expressly authorised by these Specific Regulations (SR) and where appropriate, the General Regulations (GR).
- (b) Where a regulation is marked (H) the onus is on the competitor to provide supporting information from the relevant brochure or official documents issued by the vehicle manufacturer; importer; or distributor.

9.3 ELIGIBILITY/DEFINITION

A four-wheel drive *Automobile* as defined in GR 1 with provisions for at least two crew members, and of a series production type of which not fewer than 25 identical units (with regard to engine/chassis) have been marketed in Australia, or recognised by FIA and which complies with GR 2-8, 11-21, 23-30 and, if required by regulations for a specific event, GR 31.

9.4 COACHWORK

- (a) Coachwork beneath the bumper bar mounts may be removed or modified.
- (b) Bumper bars may be replaced with a bull bar/brush guard.
- (c) The addition of separate flares or wheel arch extensions to the original mudguards is permitted.
- (d) Vehicles first registered for competition in Class 7 prior to 1 January 1987 and which have been modified in the area of the wheel arches may be submitted to *Motorsport Australia* for dispensation.
- (e) All additional accessories inside the habitacle are authorised without restriction, such as those concerning the aesthetics or the inside comfort, e.g., lighting, heater, radio etc., as well as those enabling easier or safer driving of the car, e.g., screen washers, mirrors etc., provided that they do

not affect, even indirectly, the mechanical performance of the engine, steering, transmission, road holding or braking.

- (f) Roof vents may be fitted, but they must be in the forward one-third of the roof, with their opens side facing forward, and their vertical opening not greater than 10cm.
- (g) The use of chassis/cab vehicles without rear bodywork, and of tray-top vehicles, is prohibited.

9.5 INTERIOR

Interior trim, seats and floor coverings are free. The front door trim, if removed, is required to be replaced by flush-fitting rigid material. Insulating material may be removed from the floor. Instruments may be added. The steering wheel is free.

9.6 CHASSIS

The original chassis must be retained unmodified, save that material for strengthening purposes may be added, as may be material to enable the addition of shock absorbers and hydraulic bump stops (see SR 3.9).

9.7 ENGINE

- (a) The original engine block must not be changed. The cylinder bore may be increased so as to accommodate up to the largest oversize piston nominated by the manufacturer (H) as being available for the model. Planing of the cylinder block is allowed.
- (b) Pistons, piston rings, gudgeon pins and their securing mechanisms are free. The original crankshaft and connecting rods must be retained. They may be modified only by the removal of metal or by chemical or heat treatment.
- (c) Engine capacity is limited to 6000cc (+1%) capacity for petrol engines or 7200cc (+1%) for diesel engines, inclusive of any turbo/supercharging, rotary and/or diesel correction factors.
- (d) The original flywheel may be modified only by the removal of metal or by chemical or heat treatment. Solid Flywheels may be used as a replacement for dual mass Flywheels.
- (e) Sump, filter and oil radiators are free as are oil lines.
- (f) Save for the retention of the original number, the carburettor is free. An adaptor plate may be attached to the inlet manifold to facilitate the fitment of the carburettor. Carburettor linkages are free.
- (g) The air filter and associated fittings leading to the carburettor are free. On vehicles originally fitted with fuel injection systems:
 - (i) the air filter and associated fittings leading to the inlet manifold are free;
 - (ii) the electronic or mechanical equipment involved in the management, monitoring or calibration of the injection system is free;
 - (iii) the throttle control assembly, if an integral part of the inlet manifold, must be as supplied by the manufacturer; otherwise it is free;
 - (iv) the inlet manifold and throttle butterfly, if integrated, may be modified only by removal of material from within the inlet tract; and
 - (v) fuel injectors and their method of attachment are free, save that no modification may be made to the inlet manifold to facilitate their fitment. Inlet manifolds may be modified only by the removal of material from the inlet tract.
- (h) The exhaust system is free.
- (i) Valves are free, but not their number.
- (j) Valve springs, retainers, cotters and guides are free.
- (k) Camshafts are free, but not their number, location or the number of bearings.
- (l) Engine mounts are free, but not their location or number.
- (m) Fuel pumps are free, but they may not be located in the passenger compartment unless originally sited there.
- (n) Fuel lines and fuel filters are free.
- (o) Anti-pollution equipment may be removed and any resultant holes plugged.
- (p) Fans are free.

- (q) Radiators and their fixation are free, providing the original fittings on the vehicle are maintained.
- (r) Ancillary belts and pulleys situated outside the engine are free.
- (s) The thermostat is free.
- (t) If a vehicle is originally fitted with a turbocharger or a supercharger, the induction pressure is free, as are the control devices. The operation of the intercooler must conform to the same operating type of the original intercooler (H); i.e., air-to-air etc. The position and size of the intercooler is free, save that the coachwork must not be modified to enable fitment.

9.8 GEARBOX/TRANSMISSION

- (a) The original gearbox housing and configuration must be maintained.
- (b) (H) Ratios must be as available from the manufacturer for the competing vehicle. Gearbox mounts are free as is their number.
- (c) An oil radiator and ancillary components including pump may be added. The clutch lining material is free as is the method of attachment.
- (d) Automatic transmissions may have the minimum amount of modification required to permit manual control of gear changes. This may be either by electronic or mechanical modification.

9.9 FINAL DRIVE

- (a) Differentials and transfer case must be operative and capable of driving all four wheels.
- (b) Differential action is free.
- (c) (H) Ratios must be as available from the manufacturer for the competing vehicle.

9.10 SUSPENSION

- (a) The following suspension modifications are permitted:
 - (i) one additional shock absorber per wheel may be added. Mountings for such additions may be attached to the chassis or bodywork. The minimum amount of material may be removed as is necessary for the fitment of these;
 - (ii) the original shock absorber may be modified or replaced by another;
 - (iii) the original shock absorber mounting may be moved or modified only to the extent necessary to permit the fitment of any additional shock absorber;
 - (iv) no part of any shock absorber, bump stop or its associated mounting may protrude through any external body panel (front shock absorbers/bump stops) or any body panel (rear shock absorbers/bump stops);
 - (v) suspension and spring mounting points, and all suspension components, may be strengthened by the addition of material;
 - (vi) spring hangers and shackles may not be reversed or lengthened. Springs are free subject to their retaining the original type of spring, e.g., coil, torsion bar, leaf;
 - (vii) the use of limit straps or other devices to limit the downward travel of the suspension are permitted and may be mounted by welding or bolting of brackets to the chassis and suspension components;
 - (viii) the use of hydraulic bump stops is permitted and are not regarded as shock absorbers; and
 - (ix) the removal of a minimum amount of material from a suspension spring coil tower to permit the fitment of a hydraulic bump stop.

9.11 FUEL TANK

Fuel tanks and their capacities are free, as is their location. Should a fuel tank be located in the habitacle, it must be separated from the occupants by a flame and liquid proof bulkhead.

9.12 WHEELS

Wheels are free subject to the complete wheel (see *Motorsport Australia Manual* – Technical Appendix - Definitions Technical) being covered by mudguards, or flares firmly attached to the mudguard, for at least one third of the circumference of the wheel (over the full width of the assembly)

9.13 BRAKES

- (a) The vehicle's original braking system is to be considered as the maximum allowable dimensions, however the braking system may be substituted for other braking components available from the manufacturer of the vehicle (H) or aftermarket equivalent replacement parts of the manufacturer's original parts.
- (b) If, as original equipment, the vehicle is fitted with a dual-circuit braking system, the handbrake may be removed.
- (c) The brake pads/linings may be changed.

9.14 SAFETY CAGE STRUCTURE

A safety cage structure, as specified in GR 18 must be fitted.

9.15 GENERAL

- (a) Throughout the vehicle nuts, bolts and screws may be replaced by any other nut and/or bolt and/or screw.
- (b) All gaskets are free. The make and material of bearings are free provided that they are of the original type and dimension; e.g., roller, plain, metal etc.
- (c) All fluid lines are free, as is their location and attachment (including oil, water and brake fluid lines). Any lines passing through a bulk-head must be securely grommeted. Any oil or water line passing through the habitacle must be fitted in such a way that the occupants will not be endangered should the line rupture.
- (d) The addition of relays and fuses to the electrical system is allowed. All electrical cables are free.
- (e) The make and capacity of the battery is free, as is the make and capacity of the generator. The nominal voltage of the electrical system must be retained.
- (f) The ignition coil, condenser and distributor, ignition points, spark plugs and all associated wiring are free subject to the ignition system remaining the same as provided by the manufacturer of the model concerned, e.g. battery/coil or magneto. The fitting of an electronic ignition system is permitted, replacing a mechanical one and vice versa. The number of spark plugs may not be increased.

10. EXTREME 4WD

Highly-modified 4WD

10.1 ELIGIBILITY/DEFINITION

- (a) A four-wheel drive *Automobile*, as defined in GR 1, and which may be fitted with either one or two seats. The original shape of the body must be from a series production *Automobile* which complies with GR 2-30 and, if required by regulations for a specific event, GR 31.
- (b) All modifications are allowed, save for the restrictions specified hereunder.

10.2 COACHWORK/CHASSIS

- (a) The body must be derived from a production four-wheel drive vehicle and substantially resemble it.

10.3 SAFETY CAGE STRUCTURE

A safety cage structure, as specified in GR 18 or alternatively must incorporate a frame which complies with GR 9.

10.4 ENGINE

- (a) The engine is free, except for the capacity.
Engine capacity must not exceed:
 - (i) 7000cc (+1%) for naturally aspirated petrol engines;
 - (ii) 6000cc (+1%) for supercharged petrol engines inclusive of any supercharging/rotary multiplication factors; or
 - (iii) 7200cc (+1%) for diesel engines, inclusive of any supercharging multiplication factors.
- (b) Modifications to the engine are free.

- (c) The location of the engine is free, save that no part of the cylinder block may extend across a line drawn at right angles to the longitudinal axis of the car, at a point halfway between the front and rear wheel hub centres.

10.5 TRANSMISSION

- (a) The gearbox, housing, transfer case, differentials and axle housings are free save that the 4wd system must be operational and capable of driving all 4 wheels.

10.6 ELECTRICAL

The requirements of GR 24-26 must be complied with.

10.7 EXTREME 4WD BUGGY

Extreme 4WD Buggy is a sub-class of Extreme 4WD being a one or two-seat four-wheel drive *Automobile*, as defined in GR 1, and which must comply with the following:

- (a) Buggy Classes; Article 1. GENERAL
- (b) Extreme 4WD Article:
 - (i) 10.4 (a) and (b);
 - (ii) 10.5; and
 - (iii) 10.6.

SXS (Side X Side)

11. SXS (SIDE X SIDE)

11.1 GENERAL

- (a) Each vehicle must comply with these regulations, applicable Motorsport Australia Technical Appendix and the Off Road (GR).
- (b) Each vehicle must remain in standard specification as produced by the manufacturer unless a freedom is provided for below in these regulations.
- (c) The onus is on the competitor to provide evidence of eligibility, which may include supporting information from the relevant brochure or official documents issued by the vehicle manufacturer/importer/distributor.

11.2 ELIGIBILITY/DEFINITION

- (a) The SXS class is for off road recreational vehicles with a seating capacity of two crew members, located side by side, steered by a steering wheel.
NOTE: Two crew members must be seated at any point in time during competition.
- (b) A SXS vehicle may be either two or four wheel drive. SXS vehicles, as defined must only be eligible to compete as a SXS.
- (c) The current eligible vehicle manufacturers and models are listed in Attachment 1: Eligible SXS Vehicles List.
- (d) The class will be sub-divided into two parts:
 - (i) **SXS Pro:** an engine of a capacity not exceeding 2050cc including the relevant multiplication factor/s if supercharged/turbocharged.
 - (ii) **SXS Sport:** a naturally aspirated engine of a capacity not exceeding 1200cc.
- (e) It is permitted to fit a forced induction device in compliance with the following:
 - (i) The forced induction device and associated fitment kit used is one produced and sold by the Original Equipment Manufacturer (OEM) as a kit and listed as approved by Motorsport Australia for a SXS model, refer Appendix 1.2 Approved SXS Forced Induction Kits.
 - (ii) Be fitted with each OEM component part as per the OEM kit.
 - (iii) Each component fitted must be in compliance with the OEM instructions.
 - (iv) Aftermarket turbo kits or non-approved manufacturer turbo kits are not permitted.

(v) Triennial Inspection is mandatory following forced induction device fitment. The Triennial Inspection must occur prior to the vehicles next race.

(vi) The SXS will be classified as a SXS Pro.

NOTE: A scrutineer must inspect a vehicle and note in log book 'forced induction kit fitted and relevant OEM documentation sighted'.

The onus is on the competitor to prove that the forced induction kit and fitment is as per the OEM requirements, which may require the production of documentation to prove the purchase was from an OEM supplier.

(f) The nominal cylinder capacity for a supercharged/turbocharged engine must be multiplied by a factor of 1.7 for spark ignition engine and by 1.5 for Diesel engines.

(g) It is permitted to replace any OEM component or part with any other OEM component or part from the same SXS Model (regardless of year of manufacture). The OEM component or part must only be fitted and used in accordance with the OEM instructions requiring no modifications to that component/part or any other component/part except where permitted within these regulations.

11.3 COACHWORK

(a) The bodywork must be original in appearance, though original and aftermarket accessories may be fitted, such as a windscreen, provided the original shape can be identified.

(b) A securely fitted panel of rigid material such as aluminium or GRP must be fitted to the door opening to restrain limbs within the confines of the vehicle.

(c) A roof plate complying with GR13 must be fitted.

(d) The use of chassis/cab vehicles without rear bodywork, and of tray-top vehicles, is prohibited on the grounds of safety.

(e) Rear tray and rear fascia plastics may be modified or removed to permit the fitment of roll cage and/or accessories including aftermarket exhaust, spare tyre and rear mount radiator.

11.4 INTERIOR

The interior of the vehicle is free except those items regulated by the *Motorsport Australia* Technical Appendix, including seats and harnesses. A replacement seat must comply with GR12. Safety nets are required as per GR19.

11.5 CHASSIS

(a) The original chassis must be retained and be unmodified save for the addition of material for strengthening purposes or for the addition of the Safety Cage.

(b) A Safety Cage complying with Schedule J (refer Technical Appendix), and approved by *Motorsport Australia*, must be fitted and must incorporate at least two uninterrupted door bars. The upper door bar must be fitted predominantly horizontally and as high as practicable. Additional reinforcing bars are recommended.

NOTE: The original safety cage provided by the vehicle manufacturer will likely not comply with this requirement and may need to be replaced. Refer to *Motorsport Australia* Technical Department if in doubt.

(c) The Safety Cage must be designed and constructed to enable both crew to self-extricate from the vehicle within a 10 second period.

(d) The vehicle firewall must comply with the requirements of GR 2.

11.6 ENGINE

(a) The original engine block/case and cylinder head must be utilised.

(b) Exhaust requirements must be as per GR 23.

(c) The engine cooling system is free.

(d) Re-mapping of the ECU for a vehicle that is fuel injected is permitted.

(e) Naturally aspirated vehicles competing in the SXS Sport class with an engine capacity not exceeding 1200cc:

(i) the induction and air cleaner assemblies upstream of the throttle body or carburettor systems are free.

- (ii) the ECU control and output for the ignition system is free. The original components and sensors for any fuel injection and ignition system must be used. No additional sensor is permitted to be used for the engine and engine systems.
- (iii) The fuel injector rail and fittings are free. Fuel injectors must be original components.
- (f) Supercharged/turbocharged vehicles competing in the SXS Pro class with an engine capacity not exceeding 2050cc including the relevant multiplication factor/s:
 - (i) For each turbocharged engine the induction and air cleaner assembly upstream of the turbocharger compressor housing inlet are free. The ECU control and output for the ignition system is free. The original components and sensors for any fuel injection and ignition system must be used. No additional sensor is permitted to be used for the engine and engine systems.
 - (ii) Relocation of the standard intercooler or heat exchanger is permitted.
 - (iii) The fuel injector rail and fittings are free. Fuel injectors must be original components.

11.7 GEARBOX & TRANSMISSION

- (a) **Except for bearings and bearing carriers which are free**, the original transmission / gearbox and differential/s must be used.
- (b) The vehicle is required to have a reverse gear fitted.
- (c) Transmission / gearbox mounts are free as is their number.
- (d) A transmission /gearbox oil radiator or cooler including pump and ancillary items may be added.
- (e) The clutch is free.
- (f) Each drive shaft is free.

11.8 SUSPENSION & STEERING

- (a) Only one shock absorber must be mounted per wheel, but otherwise each shock absorber is free.
- (b) Each shock absorber mounting point may be moved.
- (c) Chassis suspension and spring mounting points, and all suspension components may be strengthened, by the addition of material to the original components.
- (d) Front and rear suspension arms are free providing:
 - (i) The maximum permitted outside tyre to outside tyre measurement at any point in the complete range of suspension travel must not exceed 2100mm. Refer Drawing 1.
 - (ii) The maximum permitted outside tyre to tyre measurement must be inclusive of any permitted suspension arm, wheel offset and wheel spacer fitted.
 - (iii) The wheelbase of the vehicle may not be increased more than 4.5% from standard.
- (e) Ball joints to the hub must be free.
- (f) Suspension springs are free subject to their retaining the original type of spring, e.g., coil, torsion bar or leaf.
- (g) Elastomeric suspension bushes are free.
- (h) Each sway bar is free. Additional sway bars may be added.
- (i) The use of limit straps or other devices to limit the downward travel of the suspension is permitted.
- (j) Power steering is permitted and may be added.
- (k) For Polaris RZR 800 vehicles, wheel hubs may be replaced.

Drawing 1

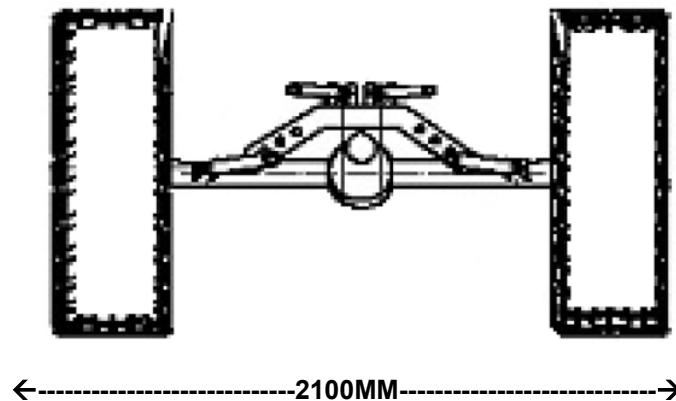

11.9 FUEL & FUEL TANK

- (a) Fuel tank(s) and their location is/are free subject to compliance with GR5 and GR27.
- (b) Additional or auxiliary fuel tanks may be added subject to compliance with GR5 and GR27.
- (c) Fuel pumps, their location and number of pumps is/are free. Should a fuel pump be located in the habitacle, it must be separated from the occupants by a flame and liquid proof bulkhead.
- (d) *SXS is permitted to use only Pump Fuel as defined by Motorsport Australia in Schedule G (refer GR27 and Technical Appendix).*

11.10 WHEELS & TYRES

- (a) Each wheel and tyre is free.
- (b) Each tyre must be fitted in accordance with Schedule E (refer Technical Appendix).
- (c) The use of a wheel spacers to a maximum thickness of 60mm.

11.11 BRAKES

- (a) The brake pads/linings may be changed.
- (b) The addition of power assistance may be added or, if not fitted originally, a dual-circuit braking system.
- (c) A handbrake may be added.
- (d) A system to adjust front to rear brake bias may be added.
- (e) Turning or steering brakes are not permitted.

11.12 ELECTRICAL

- (a) The addition of relays and fuses to the electrical system is allowed.
- (b) All electrical cables are free.
- (c) The make, capacity, number and location of the battery/ies is free.
- (d) The make and capacity of the alternator is free.
- (e) The nominal voltage of the electrical system must be retained.
- (f) A battery isolation switch complying with GR 25 must be fitted.
- (g) The location of the ECU is free.

11.13 MISCELLANEOUS

- (a) Throughout the vehicle nuts, bolts and screws may be replaced by any other nut and/or bolt and/or screw.
- (b) All gaskets are free.
- (c) The make and material of bearings are free provided that they are of the original type and dimension; e.g. roller, plain, metal etc.

- (d) All fluid lines are free, as is their location and attachment. Any lines passing through a bulk-head must be secured and protected by a grommet or fitted with a suitable bulkhead fitting. Any oil or water line passing through the cockpit must be fitted with protection in such a way that the occupants will not be endangered should the line rupture.

Off Road Kart

12. OFF ROAD KART

12.1 GENERAL

- (a) Each vehicle must comply with these regulations, *Motorsport Australia Manual* Technical Appendix and the Off Road GR where specifically mentioned.
- (b) Each Junior Kart must remain unmodified and in compliance with all aspects of its *Motorsport Australia* Recognition Document except for the freedoms permitted by these regulations. Any modification or tuning practice which is not specifically permitted by these regulations is expressly forbidden.

12.2 ELIGIBILITY/DEFINITION

The aforementioned rules will apply as per the Off Road Kart Standing Regulations outlined in the *Motorsport Australia Manual* Off Road Appendix.

12.3 COACHWORK

- (a) Coachwork must comply with the vehicles Recognition Document.
- (b) Mud flaps must comply with the requirements of GR 31 and must be affixed to the vehicles with bolts and fender washers to resist folding back or tearing of the mud flap.
- (c) Skid plates must comply with the requirements of GR3.

12.4 INTERIOR

(a) Seats

Only manufactured race seats must be permitted. Full containment seats are highly recommended. Plastic seats are prohibited. Each seats must be sized appropriately for driver's height and weight (i.e. Child sized seats). Each seats must be securely mounted to the frame of the automobile and properly reinforced as to keep the seat from moving in relationship to the frame. Headrests designed and installed to prevent whiplash are mandatory on all *Automobiles*. Headrests must be constructed as per GR 12. Each seat must be centrally located in the vehicle.

12.5 CHASSIS

- (a) Each chassis must comply in all respects to the specific vehicles Recognition Document and Safety Cage Certification approved by *Motorsport Australia* where applicable.
- (b) Roll Bar Padding: Where the helmet of an occupant could come into contact with the Safety Cage Structure, protective padding must be fitted to that area, which complies with Schedule J (refer Technical Appendix).

12.6 ENGINE

- (a) Must comply in all respects to the specific vehicles Recognition Document except where a freedom is provided by these Regulations
- (b) Cooling: Junior Kart 200A & Junior Kart 200B
 - (i) A fine metal screen may be added to deflect dirt.
- (c) Lubrication: Junior Kart 200A and Junior Kart 200B
 - (i) Oil is free
- (d) The exhaust system is free, save, it must be configured such that the sound emitted when measured 30m from the track edge does not exceed 95dB(A) unless event regulations set a lower limit.
- (e) Carburettor
 - (i) No modifications of any kind may be made to the carburetion system, save for jetting which is free. No material may be added or removed;
 - (ii) The carburettor bore, venturi, air or fuel passages may not be enlarged;

- (iii) Stock fuel bowl must be used; and
- (iv) A throttle return spring must be fitted on the carburettor and at the foot pedal.
- (f) The air filter and inlet to the carburettor is free.
- (g) A pull starter or electric starting system may be used.
- (h) Fuel Injection: RS450 Trophy Karts
 - (i) Fuel injection is permitted if it was a stock system included with the engine by the OEM;
 - (ii) No modifications to the throttle body, manifold, injectors or sensors are allowed; and
 - (iii) Aftermarket controllers are allowed but must be approved by the AORCom
- (i) Clutch: General
 - (i) The engine clutch must be mounted in the stock location;
 - (ii) Clutch tuning is free providing that all tuning parts used are commercially available.
- (j) Junior Kart 200A:
 - (i) Clutch tuning is limited to springs, weights, ramps, and sliders only;
 - (ii) The mandated clutch is the Comet Series 20 (six inch diameter only);
 - (A) The Comet TAV2 Torque-A-Verter may also be used;
 - (B) The use of any other manufacturer's components is prohibited;
 - (C) No modifications may be made to either system. This includes no modifications of any kind to the drive cones, plates, and shafts, including changes in profiles, diameters, or materials;
 - (D) No components may be added or removed;
 - (E) The brand of a replacement belt is free; and
 - (F) The clutch cover may be removed.
- (k) Junior Kart 200B , RS250 and RS450 Trophy Karts
 - (i) The clutch is free.

12.7 GEARBOX AND TRANSMISSION

- (a) General
 - (i) Final drive gearing is free;
 - (ii) Four wheel drive is prohibited; and
 - (iii) Chain drive is mandatory.
- (b) Junior Kart 200A:
 - (i) A gear change transmission is not permitted.
- (c) Junior Kart 200B, RS250 and RS450 Trophy Karts:
 - (i) Transmission must remain stock as delivered by manufacturer for this model of engine; and
 - (ii) Each changes is only permitted with AORCom approval.
- (d) Drive parts:
 - (i) Rear drive must be spool type only;
 - (ii) Engine to transmission must be all one piece (as a factory motorcycle or quad);
 - (iii) Chain drive is required from the driver to the driven sprocket;
 - (iv) 1 constant velocity joint is permitted; and
 - (v) Only 1 half shaft/drive shaft with 2 universal joints is permitted.

12.8 SUSPENSION AND STEERING

- (a) The steering system must comply with the vehicles Recognition Document. The system must work as the manufacturer intended with all bolts and parts tightened.
- (b) Shocks:
 - (i) There must be at least one and only one shock absorber per wheel in working condition at the start of each race;
 - (ii) No internal or external bypass shocks are allowed;
 - (iii) Shock valving and fluid type are free;
 - (iv) Air shocks are prohibited;
 - (v) Reservoirs are allowed with a maximum size of 50mm x 200mm;
 - (vi) Dual rate springs are permitted;
 - (vii) Shocks must not be adjusted while kart is in motion;
 - (viii) Externally adjustable rebound and compression (clicker) shocks are permitted; and
 - (ix) Shocks must have a maximum of travel of 300mm.
- (c) Bump stops:
 - (i) Suspension bump stops must be of the solid type; and
 - (ii) Bump stops must not be attached to any moving suspension parts.

12.9 FUEL AND FUEL TANK

- (a) The fuel tank must comply with the vehicles Recognition Document; and
- (b) Pump fuel as defined by Schedule G (refer Technical Appendix) must be used.

12.10 WHEELS AND TYRES

Wheels and tyres must comply with the vehicles Recognition Document.

12.11 BRAKES

- (a) Turning or cutting of brake components must not be permitted;
- (b) Brake systems must be in safe operating condition during the entire event. If brake system problems do occur during the event they must be repaired before continuing in competition;
- (c) Front brakes are permitted;
- (d) Brakes may be hydraulic or cable activated.

12.12 ELECTRICAL

- (a) Ignition: General:
 - (i) Each vehicle must have a positive action on/off switch in good working order. The switch must be highlighted in red, be labelled "ignition on/off," and be located within easy reach of the driver and from the outside of vehicle; and
 - (ii) Spark Plugs are free.
- (b) Junior Kart 200A & Junior Kart 200B
 - (i) The ignition must comply with the vehicles Recognition Document. No modifications of any kind may be made to the ignition system unless specified herein.
- (c) RS450 Trophy Karts
 - (i) The ignition system is free; however aftermarket ignitions must be readily available and pre-approved by AORCom.

12.13 MISCELLANEOUS

- (a) No titanium or any other exotic materials may be used anywhere in the vehicle; and
- (b) All fuel and brake line hoses including metal lines and fittings must be clamped and/or safety wired.

Attachment 1 – SXS VEHICLES LIST

1.1 Eligible Vehicle List

- (a) Polaris (RZR models)
- (b) Can Am (Commander and Maverick models)
- (c) CF Moto - (Z6, Z6 Spec R)
- (d) Yamaha (Rhino & YXZ models)
- (e) Arctic Cat –Wild Cat 1000i H.O
- (f) BBM1100 Cyclone

1.2 Approved SXS Forced Induction Kits

- (a) Yamaha GYTR Turbo Kit for Yamaha YXZ models.

Attachment 2 – SPORTSLITE RESTRICTOR

Each forced induction engine must be fitted with an inlet air restrictor. All the intake air for the engine must pass through this restrictor. The requirement for a component seal may be applied by *Motorsport Australia* or an Event Organiser.

1.3 For each Turbocharged engine the following applies:

- (a) The maximum internal diameter of the restrictor must not exceed 32mm, maintained for a minimum distance of 3mm measured downstream of a plane perpendicular to the rotational axis situated at a maximum of 50mm upstream of a plane passing through the most upstream extremities of the wheel blades, this distance being measured along the neutral axis of the intake duct, Refer Drawing 1.
- (b) The internal diameter must be complied with, regardless of the temperature conditions.
- (c) The external diameter of the restrictor at its narrowest point must be less than 39mm, and must be maintained over a distance of 5 mm to each side, Refer Drawing 1.
- (d) The mounting of the restrictor onto the turbocharger must be carried out in such a way that two fasteners, either screw, bolt or cap screw, have to be entirely removed from the body of the compressor, or from the restrictor, in order to detach the restrictor from the compressor housing, Refer Drawings 1 and 2.
- (e) Attachment by means of a needle screw is not authorised.
- (f) It is permitted to remove material from the compressor housing, and to add it, for the sole purpose of attaching the restrictor onto the compressor housing.
- (g) Each restrictor must be made from a single material and may be pierced solely for the purpose of mounting.
- (h) In the case of an engine with two turbochargers or two parallel compressor housings, for each compressor the maximum internal diameter of the restrictor must not exceed 21mm.

1.4 For each other forced induction engine (i.e. a supercharger):

- (a) The maximum internal diameter of the restrictor must not exceed 32mm.
- (b) Each restrictor mounting for an engine with a non-exhaust driven supercharger will be determined by *Motorsport Australia*. Each competitor using a non – exhaust driven supercharger must apply to *Motorsport Australia* for a determination on the fitment of a restrictor.

DRAWING 1: TURBOCHARGER RESTRICTOR REQUIREMENTS

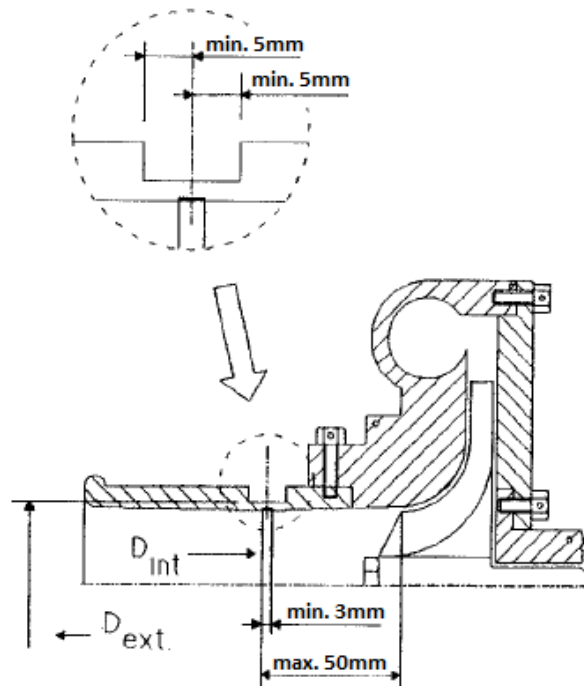

DRAWING 2: TURBOCHARGER RESTRICTOR ALTERNATE MOUNTING

