

## CIRCUIT RACE APPENDIX

## REFUELLING IN PIT LANE

Modified Article	Date of Application	Date of Publication
Art. 1	01/01/2025	01/01/2025

A capitalised and italicised word in this document is defined in the FIA International Sporting Code (Code) or the National Competition Rules (NCR), including their Appendices.

Any HEADING is for reference only and has no regulatory effect.

## PART 1 - REFUELLING IN PIT LANE AT A NATIONAL COMPETITION

## 1. GENERAL

Unless otherwise approved by *Motorsport Australia*, at a *National Competition* where the *Supplementary Regulations* permit refuelling of an *Automobile* during any testing, practice, qualifying or race, this must be conducted in pit lane and the following procedures must be adopted.

Refuelling of an *Automobile* in pit lane is permitted by use of an overhead refuelling rig (Overhead Rig) only.

Unless specified otherwise in *Supplementary Regulations*, only those involved in the refuelling process may be in pit lane during refuelling.

Refuelling of an *Automobile* on the circuit is prohibited.

Refuelling of an *Automobile* in the pit garage or paddock is prohibited during any session in which the *Automobile* is entered.

Any refuelling of an *Automobile* outside of a session must be conducted either with the *Automobile* totally within a pit garage or in the area of the paddock specifically designated for the purpose of refuelling; and must be completed with the engine turned off.

## 2. SAFETY

## 2.1 Fuel Storage

The area of the pit garage in which a fuel reservoir is situated must be adequately ventilated and have unimpeded access from front and rear of the pit garage. A minimum quantity of extinguishment as required by the Circuit Race Standing Regulations must be available for use in each pit garage. The area must be clean and free of any potentially flammable material, e.g. paper, rag, oily fabric.

## 2.2 Pit Crew

Any refuelling-related procedure will require a maximum of 4 pit crew members to attend the *Automobile* who will only be permitted to perform the following tasks:

**1 fire attendant** – stand near the *Automobile* and the refuelling equipment with the fire extinguisher ready to operate;

**1 emergency cut-off valve attendant** - hold the emergency cut-off valve open during the refuelling operation;

**1 refueller** – handle and operate the refuelling nozzle;

**1 hose attendant** (optional) – hold the refuelling hose over the rear of the *Automobile* if required

Each pit crew member must be attired in accordance with the requirements of *Schedule D* for a refuelling operation.

Any other pit crew member whose task places them within 1 metre of the refuelling valve on an *Automobile* (e.g. Car Controller, Driver Assistant) must be attired as listed above for refuelling crew.

### 2.3 Emergency Cut-Off Valve

It is mandatory for an Overhead Rig to be equipped with a ball-cock or similar fast action valve which must work on the “dead man” principle. This valve must be attached directly to the fuel reservoir (see Diagram 2). When pressure on the handle of the cut-off valve is released, the valve must immediately close, stopping the flow of fuel from the reservoir. The closing principal must not rely on the action of gravity alone.

### 2.4 Approval of Intallation and Equipment

All equipment must be specifically approved by the Chief Scrutineer or their nominee prior to any *Competition* during which refuelling is permitted in pit lane. *Supplementary Regulations* will provide details of time and place for the inspection.

### 2.5 Earthing

During any refuelling operation, it is mandatory that the *Automobile* be electrically connected to earth, as follows:

The *Automobile* refuelling receiving unit must be connected to a ground/earth point of the *Automobile*; and;

The refuelling system (including tower, tank, hose, nozzle, valves and vent bottle) must be connected to a grounding connection for the duration of the session.

### 2.6 Automobile Movement

The *Automobile* must be stationary at all times during refuelling.

The *Automobile* must have its engine switched off during refuelling.

## 3. DRY-BREAK COUPLING

Unless specifically approved by *Motorsport Australia* and published in the event regulations, a refuelling operation must be conducted utilising a Siamese dry-break system. A dry-break system is deemed to consist of two separate units, the receiving unit and the probe unit together with the associated hoses, valves etc. The general design of the receiving unit and probe unit is included at Diagram 1. A male probe unit must be fitted to each refuelling hose. A female receiving unit must be fitted to the *Automobile* in accordance with the requirements of the technical regulations for the relevant category.

It is permitted to use one receiving valve only to permit the entry of fuel into the tank, and one receiving valve for connection to the return vent.

All refuelling equipment must be maintained in good working order. Any O-ring must be regularly inspected and replaced if there is any sign of expansion or damage. Any spring and track must be regularly inspected and kept lubricated during those times the refuelling valves are not in operation.

## 4. OVERHEAD REFUELLING RIG

An Overhead Rig must store fuel in a single rigid reservoir (see Diagram 2).

An *Automobile* must be refuelled via a single flexible hose fitted with a male probe unit of standard design (see Diagram 1) with a single return vapour line to the Overhead Rig.

The maximum height of any part of the Overhead Rig which contains fuel is 2 metres above the pit lane. Only a non-fuel holding connection and/or vent is permitted above this height.

The maximum capacity of the reservoir including the delivery hose is 220 litres which must in all circumstances allow 10% ullage (air space).

A single delivery hose, which must be of a flexible rubber or a fuel resistant reinforced plastic material must be connected to the “dead man” valve.

The flexible part of the delivery hose must be a minimum of 2.5 m in length and of an *ID* no greater than 50 mm (2”).

The flexible hose must be connected to a male probe. A solid connecting sleeve (maximum length 300 mm) is permitted between the hose and the probe to assist with ease of handling.

Each part of the refuelling system, including the male probe, the flexible hose, any connection sleeve, the cut-off valve and the reservoir must be electrically continuous and efficiently grounded.

The reservoir must be vented via an explosion safe shielded vent.

A filling orifice (maximum 50 mm diameter) may be fitted to the main reservoir. Any refilling of the main reservoir must be conducted in accordance with civil Occupational Health and Safety regulations.

Artificial pressurisation of the reservoir is prohibited.

The vent must be open to the atmosphere and only atmospheric pressure may be exerted on the fuel in the main reservoir.

Any device which changes the ambient temperature of the fuel is prohibited.

The Overhead Rig must not be moved if containing fuel and must be completely drained before moving.

A fire attendant must be “ready for action” during any reservoir refilling operations.

The reservoir, return and delivery hose, must be in pit lane, close to the *Automobile’s* garage at all times when in use.

The reservoir must be tethered from 2 opposing points on top of the reservoir to a point above this on a building or structure substantial enough to support the full reservoir.

## 5. VENTING DURING A REFUELLING OPERATION

In a refuelling operation:

The fuel tank/s of the *Automobile* must be vented through a dry-break coupling (see Diagram 1) by a return vent integrated with the filler coupling as a Siamese unit.

The return vent must allow a fuel tank of an *Automobile* to be vented to the ullage space in the reservoir of the Overhead Rig (see Diagram 2).

Maximum internal diameter at vent hose is 50 mm (2”).

The vent hose must only return to the reservoir.

The reservoir must be vented externally to any pit garage.

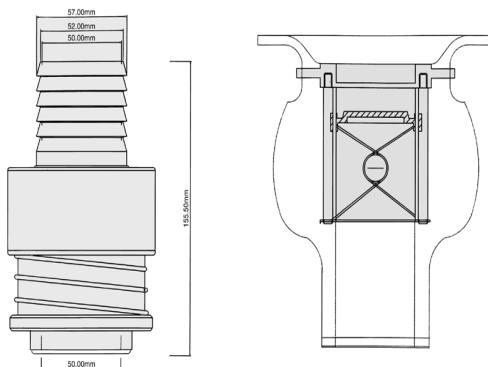

**Diagram 1:**  
General design of  
Dry-break coupling  
(probe and receiver unit)

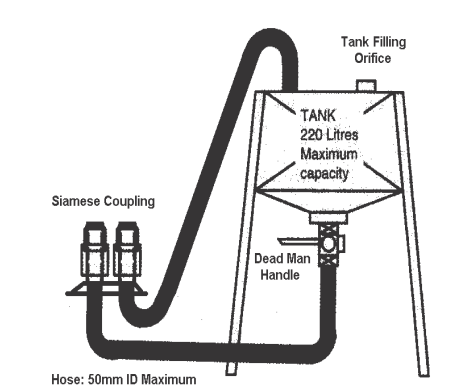

**Diagram 2:**  
Example: Overhead Rig with fuel  
hose and vent return.

## PART 2 - REFUELLING IN PIT LANE AT A CLUB/STATE COMPETITION

### 1. GENERAL

At a Club/State Competition where the *Supplementary Regulations* permit refuelling an *Automobile* during any testing, practice, qualifying or race, this must be conducted in pit lane and the following procedures must be adopted.

Refuelling of an *Automobile* in pit lane is permitted by use of an Overhead Rig or a fuel drum/s as detailed below (Drum Rig).

Refuelling of an *Automobile* on the circuit is prohibited.

Only those involved in the refuelling process may be in pit lane during refuelling.

There must be a minimum of 2 metres gap between *Automobiles* in the pit lane before refuelling is permitted to begin or continue on either *Automobile*.

No spark emitting tools are permitted in the pit lane during any session where refuelling is permitted. (eg. electric or battery-operated tools, battery jump packs etc)

Refuelling of an *Automobile* in the pit garage or paddock is prohibited during any session in which that *Automobile* is entered.

Any refuelling of an *Automobile* outside of a session must be conducted either with the *Automobile* totally within a pit garage or in the area of the paddock specifically designated for the purpose of refuelling; and must be completed with the engine turned off.

### 2. SAFETY

#### 2.1 Fuel Storage

The area of the pit garage in which a fuel reservoir is stored must be adequately ventilated and have unimpeded access from front and rear of the pit garage. A minimum quantity of extinguishment as required by the Circuit Race Standing Regulations must be available for use in each pit garage. The area must be clean and free of potentially flammable material, e.g. paper, rag, oily fabric.

#### 2.2 Pit Crew

Any refuelling-related procedure will require 3 pit crew members to attend the *Automobile* who will only be permitted to perform the following tasks:

**1 fire attendant** – stand near the automobile and the refuelling equipment with the fire extinguisher ready to operate;

**2 hose attendants** – both must assist in the moving of the fuel drum into and out of pit lane. During refuelling, 1 attendant must operate the pump, whilst the other must control the fuel connection or nozzle and the flow of fuel into the *Automobile*.

Each pit crew member must be attired in accordance with the requirements of Schedule D for a refuelling operation.

Any other pit crew member whose tasks place them within 1 metre of the refuelling nozzle on an *Automobile* (e.g. Car Controller, Driver Assistant) must be attired as listed above for refuelling crew.

#### 2.3 Approval of Installation and Equipment

All equipment must be specifically approved by the Chief Scrutineer or their nominee prior to any *Competition* during which refuelling is permitted in pit lane. *Supplementary Regulations* will provide details of time and place for the inspection.

#### 2.4 Earthing

During any refuelling operation, it is mandatory that the *Automobile* is electrically connected to earth prior to the fuel hose being connected to the *Automobile* and remain connected for the duration of the refuelling operation.

#### 2.5 Automobile Movement

The *Automobile* must be stationary at all times during refuelling.

## 2.6 Position of Crew and Equipment

Other than the Car Controller, each crew member and all equipment must remain in the pit garage until the *Automobile* has stopped in the pit bay. Once the *Automobile* has stopped, a wheel chock may be placed behind a wheel to stop the *Automobile* rolling. Where refuelling is to be conducted, the *Automobile's* engine must be switched off, the *Driver* must exit the *Automobile* and return to the pit garage before the refuelling process begins.

## 2.7 Minimum Pit Lane Time

Any pit stop that includes any amount of refuelling of an *Automobile* will require that *Automobile* to take a minimum of 5 minutes from when it enters the pit lane until it exits the pit lane.

## 2.8 Refuelling more than 60 litres

If an *Automobile* requires more than 60 litres of fuel during its refuelling pit stop, then more than one Drum Rig will need to be used. It is prohibited to refill a used refuelling drum, or swap the drum pump, from one drum to another during a pit stop. If a refuelling drum becomes empty, the drum, pump and lines must be disconnected from the *Automobile*, and that Drum Rig must be returned to the pit garage. The second Drum Rig may then be moved into pit lane and refuelling restarted. It is not permitted to have 2 Drum Rigs per *Automobile* in the pit lane at the same time.

## 2.9 Refuelling under Safety Car or Red Flag

It is prohibited for any *Automobile* to enter pit lane to begin a refuelling pit stop under:

Safety Car conditions, i.e. after the SC boards and yellow flags have been displayed until after crossing the *Control Line* at the Safety Car restart; or

red flag conditions.

## 2.10 Fuel Spill

If any fuel is spilt during the refuelling process, the refuelling must immediately stop and the fuel spill must be cleaned up. Refuelling may only continue once the spill has been cleaned up. Any spilt fuel must be cleaned up before refuelling is considered to be complete. Any fuel spill during a refuelling pit stop may be referred to the Stewards.

## 2.11 Fuel Leak

If a Drum Rig or an *Automobile* begins leaking fuel at any time during the refuelling process, refuelling of that *Automobile* must immediately stop. The fuel spill must be cleaned up and the fuel leak must be repaired to the satisfaction of the Chief Scrutineer or their nominee before refuelling is permitted to restart. Any *Automobile* leaking fuel will be prohibited to exit pit lane to re-enter the session.

## 2.12 Refueller Briefing

It is mandatory for each pit crew member involved in the refuelling of an *Automobile* at an *Event* to attend a refuellers briefing. This briefing must contain information about the garage and pit lane refuelling processes, how to manage a fuel leak or spill, and how to manage a pit lane fire. Specific information about how to use of a fire extinguisher is mandatory.

## 2.13 Refuelling near Hot Components

If refuelling is to take place within 1 metre of an *Automobile's* wheel or exhaust outlet, the particular component must be covered during the entire refuelling process with either a fire blanket or a woollen towel that is fully saturated with water.

## 2.14 End of Refuelling

The refuelling component of a pit stop is complete when any leak has been stopped, any fuel spill cleaned up, and all equipment and pit crew have returned to the pit garage (other than the Car Controller). Only once refuelling is complete is the *Driver* permitted to return to the *Automobile*.

## 3. AUTOMOBILE USING A NON-STANDARD FUEL FILLER

An *Automobile* **not** using the standard fuel filling system as provided by the original vehicle manufacturer of that *Automobile* is only permitted to refuel in pit lane during an approved refuelling session under the following conditions:

The fuel used to refuel the *Automobile* during the pit stop must be stored in metal fuel storage drums of no more than 60 litres in advertised capacity each.

The refuelling drum must remain in the pit garage until the *Automobile* has come to a complete stop, the engine has been turned off, the *Driver* has exited the *Automobile* and the *Driver* has returned to the pit garage.

A *Driver* is permitted to become 1 of the 3 refuelling pit crew members only after exiting the *Automobile* and returning to the pit garage before the refuelling operation commences.

The fuel drum must be moved into pit lane before refuelling is to commence. The drum may only be moved into pit lane with the use of a moving trolley that has:

- a rated capacity of 150 kg or more;
- a track that is wider than the fuel drum being transported;
- the drum securely attached to the trolley in a minimum of 2 places with the attachment methods rated at more than 100 kg each; and
- both hose attendants actively supporting the drum during the process of moving it to and from the pit garage into the pit lane.

The drum must not be moved whilst fuel is being transferred.

The transferring of fuel from the approved 60 litre drum into the *Automobile* may only be performed with the use of a manually operated rotary drum pump. The drum pump must be installed into the drum using a metal fuel pick up shaft and a metal drum pump clamp through the standard threaded drum opening. Use of a plastic pump clamp is prohibited.

The fuel transfer hose must be a hose approved for use with fuel and be correctly sized to fit the outlet of the drum pump. The hose must be firmly clamped to the drum pump with a metal hose clamp.

The hose from the drum pump must be connected to the *Automobile* fuel tank via a pair of quick disconnect dry-break fittings. The quick disconnect fitting connected to the drum pump and the mating half quick disconnect connected to the fuel tank must both be self-sealing dry-break fittings suitable for use with fuel. An example of these fittings is shown in Attachment 1.

The breather hose from the *Automobile's* fuel tank must be fitted with a transparent hose approved for use with fuel. This fuel tank breather hose must be connected to the 60 litre refuelling drum's standard vent opening during refuelling. It is recommended to use quick disconnect fittings to connect the *Automobile* vent hose to the drum vent fitting with an open quick disconnect fitting on the *Automobile* vent hose and a dry-break quick disconnect fitting on the drum vent hose. An example of these fittings is shown in Attachment 1.

#### 4. **AUTOMOBILE USING THE STANDARD VEHICLE FUEL FILLER**

An *Automobile* using the fuel filling system as provided by the original vehicle manufacturer of that *Automobile* is only permitted to refuel in pit lane during an approved refuelling session under the following conditions:

The fuel used to refuel the *Automobile* during the pit stop must be stored in metal fuel storage drums of no more than 60 litres in advertised capacity each.

The refuelling drum must remain in the pit garage until the *Automobile* has come to a complete stop, the engine has been turned off, the *Driver* has exited the *Automobile* and the *Driver* has returned to the pit garage.

A *Driver* is permitted to become 1 of the 3 refuelling pit crew only after exiting the *Automobile* and returning to the pit garage before the refuelling operation commences.

The fuel drum must be moved into pit lane before refuelling is to commence. The drum may only be moved into pit lane with the use of a moving trolley that has:

- a rated capacity of 150 kg or more;
- a track that is wider than the fuel drum being transported;
- the drum securely attached to the trolley in a minimum of 2 places with the attachment methods rated at more than 100 kg each: and
- both hose attendants actively supporting the drum during the process of moving it to and from the pit garage into the pit lane.

The drum must not be moved whilst fuel is being transferred.

The transferring of fuel from the approved 60 litre drum into the *Automobile* may only be performed with the use of a manually operated rotary drum pump. The drum pump must be installed into the drum using a metal fuel pick up shaft and a metal drum pump clamp through the standard threaded drum opening. Use of a plastic pump clamp is prohibited.

The fuel transfer hose must be a hose approved for use with fuel and be correctly sized to fit the outlet of the drum pump. The hose must be firmly clamped to the drum pump with an appropriate hose clamp.

The hose from the drum pump must be connected to an auto cut-off fuel nozzle for refuelling.

The fuel nozzle must:

- have an operating automatic cut-off that clicks to the off position and stops the flow of fuel when back pressure is applied to the nozzle tip;

- be approved for the transfer of fuel;

- automatically stop the flow of fuel when the lever is released;

- be of an appropriate size to fit completely within the refuelling orifice of the *Automobile* as designed by the manufacturer; and

- be attached to the fuel filling hose using correctly sized hose and fitting and clamped with a metal hose clamp.

The refuelling drum breather hole must be open and incorporate a vent system with a gravity activated roll-over valve

# Attachment 1

---

Example of a 60 litre fuel drum



Example of a Rotary drum pump



Example of a Steel Drum Pump Clamp



Example of a plastic drum pump clamp – Prohibited.





**Example of a suitable trolley**



**Example of dry break fittings.**



**Example of auto shut off refuelling nozzle**

