

Modified Article	Date of Application	Date of Publication
Art. 9.13	01/01/2025	01/01/2025
Art. 9.14	01/01/2025	01/01/2025

A capitalised and italicised word in this document is defined in the FIA International Sporting Code (Code) or the National Competition Rules (NCR), including their Appendices.
Any HEADING is for reference only and has no regulatory effect.

1. CHASSIS

1.1 IDENTIFICATION:

Each Superkart chassis must be marked with a unique identification number/code in a visible position on a non-removable main rail or member. This number/code shall be by permanent incident or impression of numerical and/or alpha characters and shall be recorded in the kart's log book.

1.2 DIMENSIONS:

- (a) The wheelbase must be at least 1000mm and not more than 1270mm.
- (b) The track must be at least two-thirds of the wheelbase.
- (c) The overall length must not exceed 2400mm.

1.3 CONSTRUCTION:

The frame must be of all metal construction.

1.4 BUMPERS:

Each kart must be fitted with bumpers to both sides, the front and the rear. No component of the kart (other than the front fairing) may extend past either the front or rear bumpers, but may be mounted on or attached to the bumpers. The fitment of side bumpers is compulsory.

For 250 International, 250 National, and 125 Gearbox Class Superkarts:

- (a) Side Bumpers are compulsory and must comply with the following Technical Specifications (refer figure 1.4.1)
- (b) Side Bumpers must be fitted to both outside faces of the chassis-frame main rail to cover the area behind the front wheel and forward of the rear wheel and must consist in at least 2 steel elements:
 - (i) a steel tube upper bar mounted above a steel tube lower bar, - all with a minimum diameter of 16mm Steel tubing and have a minimum wall thickness of 1.5mm,
 - (ii) both bars must be connected, with a minimum of at least one additional intermediate support tube, and welded together, and presenting a vertical flat face.
- (c) Minimum length of the bars parallel to ground: 500mm for the lower bar, 400mm for the upper bar.
- (d) Height of the lower bar: 50 +/-20mm from the ground.
- (e) Height of the upper bar: 200 +/-20mm from the ground.
- (f) the upper bar shall return on to and connect to the lower bar generally as follows: at the front the return end is to angle inwards to a point no less than 100mm from the bottom bar outer face line, and at the rear the return end may be angled as per the front, or return to the bottom bar at the face line no less than 120mm forward of the rear wheel tread face.
- (g) Side Bumpers shall have at least one intermediate support between upper and lower bars of the same spec material.
- (h) Each side bumper assembly must be attached to the chassis-frame main rail by 2 points minimum. These 2 attachments must be parallel to the ground and they must be 500mm minimum apart.

- (i) Side Bumpers may be formed to replicate side pod shapes that taper inward behind the front wheels, and shall cover a minimum of two-thirds of the tread width of the dry/slick) rear tyres and front tyres while positioned at the straight ahead position.
- (j) Side bumpers within side pods of non-quadrilateral outer face shape including 'wedge' styles must conform to the preceding, save that any portion of the upper bar unable to be placed parallel to ground and below 200 +/- 20mm from the ground must replicate that side pod outer face upper extremity shape.
- (k) Side Bumpers compliant with this Regulation must be fitted to all superkarts log booked after 01/01/17, and be mandatory fitment to all superkarts in competition from 01/01/19
- (l) CIK-approved long circuit Side Bumpers are allowed for all Superkart Classes using CIK chassis.

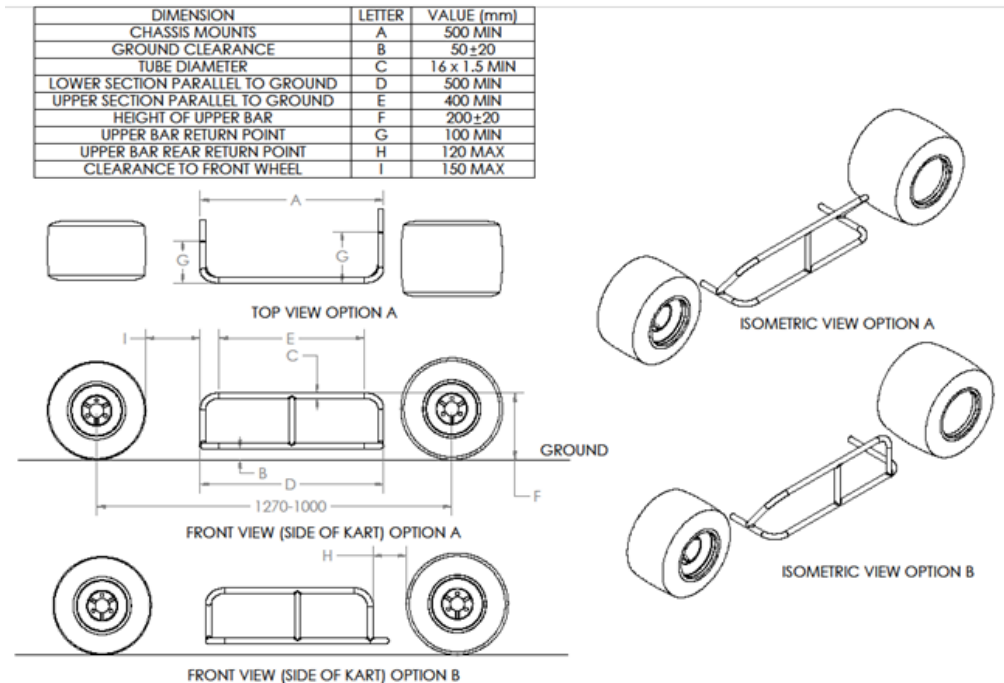

FIGURE 1.4.1

- (m) Front bumpers:
 - (i) Front bumpers must be rigid, positioned forward of the feet and mounted at the line of or forward of the front chassis rail. They may consist of single or parallel tubes, and attached fixings, tabs, brackets and supports for the front fairing are allowed.
 - (ii) The bumper must be; a minimum diameter of 16 mm Steel tubing and have a minimum wall thickness of 1.5 mm, and be mounted horizontally at a line perpendicular to the centre line of the kart and at a height no less than half way up the driver's feet when seated. Front bumpers shall have a minimum of four mountings to the main chassis placed with two either side of the front central point extremities and two at the side return ends. Front Bumper height shall not be adjustable in any way while the vehicle is in motion. Any support arms and struts shall be tubular with minimum 15mm radius edges, and have no sharp or angular points at the extremities.
 - (iii) CIK-approved long circuit Front Bumpers are allowed for all Superkart Classes using CIK chassis.
- (n) Rear Bumpers:
 - (i) Each rear bumper shall be composed of at least one bar with a minimum diameter of 18mm and a minimum wall thickness of 1.5mm in the area between the chassis main rails; the lowest bar shall with its centreline be located at a height to ground 150mm ± 20mm. The rear bumper unit must be fixed to the chassis frame in at least two points.
 - (ii) Rear wheel protection is an additional fitment to the rear bumper, and must be incorporated either as an additional unit attached to a central rear bumper, or integrated into a one-piece full width rear bumper.

- (iii) Minimum width shall be 1,080mm. The rear bumper maximum width shall not exceed the dimension between the outer flanges of the rear wheels regardless of the rear track setting.
- (iv) Rear bumper overhang shall not exceed 400mm behind the rear axle centreline. The outer ends must be located behind the rear wheels, and:
 - (A) any support struts or bars shall not have sharp or angular parts at the extremities;
 - (B) the outer ends shall comprise a minimum 120° tubular bending with a minimum radius of 50mm that returns back to the mounting leaving no exposed tube end/s;
 - (C) may be fitted in an angled, horizontal or vertical plane;
 - (D) the rear wheel protection bar/s shall be located within an area between 80mm and 260mm height to ground.
- (v) For the Non-Gearbox Stock Honda and 125cc Gearbox classes, CIK-approved rear bumpers are also allowed.

1.5 SUSPENSION:

Any suspension device is prohibited.

2. BODYWORK, SEAT AND ACCESSORIES

2.1 HEIGHT:

The maximum height of any part of the kart shall not exceed 710mm from the ground except for a structure solely designed as a head restraint with no possible positive aerodynamic effect; save that wings, including any end plates, may be not more than 1000mm above ground level.

2.2 FLOOR:

There must be a floor, made from rigid material, which extends from the seat to the front of the kart. It must be edged on each side by a tube or rim to prevent the Driver's feet sliding off the floor. It must not exceed the width of the bodywork including wings and end plates. If perforated, the holes must be of less than 10mm diameter.

2.3 SEAT:

The seat must be so designed that the Driver is well located to resist movement towards the side or front when cornering or braking. It must be firmly attached to the frame by at least four mountings of adequate strength. The installation of a CIK FIA approved seat is highly recommended.

- (a) On 250cc Gearbox Class karts (refer section 9.3), a headrest designed solely to limit the rearward movement of a Driver's head in a collision situation must be fitted.
 - (i) The position of the headrest shall be such that the helmet must contact the headrest at a point no lower than half way up the back of the helmet with the Driver in the correct seated position.
 - (ii) Fitment of a helmet pad to the headrest is permitted.
- (b) On 250cc Gearbox Class karts (refer section 9.3), the seat must incorporate a head rest. In other classes, use of a neck brace is encouraged.
- (c) The Driver must be able to see over the top of the steering wheel when seated in their normal position in the kart. The Driver's legs must occupy the front half of the kart.
- (d) It is required that the reinforcement of the seat mounting points on the seat body with metal spacers be at least 1.5mm thick and 80mm minimum diameter.

2.4 NUMBERS:

The number plate must be rectangular, at least 200mm high x 200mm wide.

The relevant colours shall be:

Class		Plate	Gearbox
125cc	Gearbox	Red	White
125cc	Stock Honda 125cc Gearbox Class	Red	Yellow

250cc/450cc	Gearbox National	White	Black
250cc	Gearbox International	Yellow	Black
125cc	Non Gearbox - Light - Heavy	White Blue	Red Yellow
125cc	Non-Gearbox Junior	High-visibility Orange (Fluro Orange)	Black

- (a) The numbers must be at least 170mm high and of 20mm stroke width.
- (b) Numbers shall be fitted to both front and rear of each kart.
- (c) The front number shall be attached to the bubble or Nassau Panel.
- (d) A third number plate shall be mounted on the side of the kart facing the timekeepers/lap scorers.
- (e) The side number shall be positioned in the area:
 - (i) no more than 500mm in front of the centreline of the rear axle;
 - (ii) with the lower edge of the numbers above a horizontal line drawn through the top edge of the rear tyre;
 - (iii) the plate itself must be vertical and parallel to the centreline of the kart.
- (f) Only advertising provided by the Organiser, not exceeding 50mm in height, may be displayed, but it must not be affixed to the lower part of the plate.
- (g) National Superkart Champions in each class as well as second and third placegetters are allocated the use of the number 1, 2 and 3 respectively as their racing number in that class for the period during which they are
- (h) National Champions or placegetters. The colours must be as specified for that class.
- (i) Karts driven by PSK and PSKJ Superkart licence holders must carry a standard "P" plate on the rear of the kart, 150mm square.
- (j) Competitors in the 125cc Non-Gearbox class may present a kart with numbers complying with AKA regulations for their first two events. Such non-compliance shall be noted in the kart's log book.

2.5 BODYWORK:

The bodywork is made up of all parts of the kart that are in contact with air, and shall include;

- (a) fairings, bubble, side pods, floor tray and aerodynamic aids or wings.
- (b) Bodywork does not include the air box, fuel tank, seat and number plates, and mechanical parts defined elsewhere.
- (c) The bodywork must be structurally sound and finished without any sharp edges that could cause injury to a Competitor.
- (d) Air vents, ducts or passages formed in bodywork or as separate elements to aid cooling or supply airflow to components shall be arranged so as not to include recessed surfaces in bodywork openings and soft and/or rolled radius to leading edges on scoops.
- (e) There shall be no external protrusions beyond the vertical surface line of the side bodywork faces.

2.6 FAIRINGS:

The fairings are free forward of the steering wheel save for classes with specific bodywork restrictions (refer article 9) and must not cover the Driver rearward of the steering wheel when seated in the kart.

Fairings must not extend in width more than 50mm beyond the quadrilateral formed by the outer edges of the front and rear tyres. They must be completely hollow except for strengthening panels.

Fairings must be of safe and sound construction and must be securely fastened to the frame. They must be firmly fixed in position and not be adjustable by any means whilst the kart is in motion. The material is restricted to:

- (a) Glass reinforced epoxy or polyesterres in;

- (i) composite construction including Kevlar and carbon fibre substrate;
 - (ii) aluminium at least 1mm thick;
 - (iii) vacuum-formed ABS at least 2mm thick or comparable non-shatterable material.
- (b) Fairings must be easily removable for scrutineering.

2.7 BUBBLE:

Perspex, plexiglass or fibreglass bubbles, of at least 1.2mm thickness may be fitted, but may not extend more than 75mm above the top of the steering wheel.

2.8 AEROFOILS/WINGS:

Aerofoils/wings may be fitted save for classes with specific bodywork restrictions (refer article 9), and must be mounted on the frame of the kart with supports of at least 13mm x 2mm tubing, or equivalent. They must be firmly fixed in position, and not be adjustable by any means, whilst the kart is in motion and must not be used as containers.

The leading edge of any aerofoil must have a minimum radius of 5mm. Recommended materials for construction of aerofoils:

- (a) Glass reinforced epoxy or polyester resin;
 - (i) composite construction including Kevlar and carbon fibre substrate;;
 - (ii) aluminium at least 1mm thick.
- (b) Steel is prohibited (refer Regulation 2.6 re. fairings).
- (c) It is mandatory to run a rear aerofoil/wing in the 250cc classes at all events.

2.9 RAIN LIGHTS:

Rain lights are mandatory for Superkarts, and shall be a unit approved by the FIA or CIK. Tail lights must be powered by a sealed battery and controlled from the cockpit by a waterproof switch.

- (a) The light must be placed in an area located 400-600mm from the ground and 100mm maximum from either side of the central axis of the kart.
- (b) It must be in working condition throughout the event.
- (c) It must be switched on when the race is declared "wet" by the Clerk of the Course.

2.10 MIRRORS:

Mirrors are optional.

3. CONTROLS

3.1 PEDALS:

Whatever the position of the pedals, they must not protrude forward of the chassis, including the bumper (refer Article 1.4).

3.2 THROTTLE:

The throttle must be operated by a pedal equipped with a return spring.

The carburettor must incorporate a throttle return spring.

3.3 HAND CONTROLS:

Hand controls for the operation of the throttle and brakes are subject to the approval of the Motorsport Australia Technical Department. Such controls shall be identified in the kart's Log Book. These controls shall only be permitted for use by Competitors with individual disabilities.

3.4 STEERING:

- (a) Steering must be effected by the operation of a full wheel or aircraft type wheel, which has a full metal frame.
- (b) Straight handle-bars are forbidden.
- (c) Detachable steering wheels are permitted provided that they meet all other requirements and are approved by the scrutineers.

- (d) Steering stops may be fitted.
- (e) The steering must be direct acting through a steel steering shaft of at least 16mm diameter if solid; or 19mm diameter if tubular having a minimum wall thickness of 1.5mm for all 125cc Classes and 2mm for 250cc
- (f) Gearbox Classes. The shaft shall be tapered, key splined, welded or bolted with a mating collar for steering wheel attachment.
- (g) The steering wheel boss must be manufactured of metal. Solid material, eg, nylon or hardwood, must be inserted through the steering column where the steering boss bolt passes through, in order to prevent the column collapsing when the bolt is tightened.
- (h) The steering shaft shall have a fail safe system to prevent it being pulled from the lower bush or bearing.
- (i) All steering linkage assembly bolts and nuts must be cottered, lock wired, or fitted with self-locking nuts (including king pin bolts).
- (j) The tie rods must be of at least 8mm OD steel rod, 10mm OD by 2mm steel tube, or 10mm OD aluminium rod, or 12mm OD by 2.6mm aluminium alloy tube. In all female components of all steering rod ends and steering tie rods, there must be an inspection hole of 1mm diameter drilled 8mm from the open end.
- (k) When assembled the inspection hole must be covered by thread.
- (l) All bolts must be of at least 6mm diameter, of high tensile steel with a shear strength of not less than 6KN.
- (m) All tie rods must have "Rose" joints or similar aircraft type universal joints. It is advisable that no steering components be chrome plated.

3.5 CLUTCH AND GEAR LEVERS:

- (a) Gear and clutch, levers or paddles shall be positioned behind the steering wheel when viewed from the Drivers position, so that they are within finger-tip reach from the steering wheel.
- (b) Gear and Clutch control by steering wheel mounted activation buttons of electric, electronic, servo, pneumatic or pressure line systems is permitted.
- (c) Further, foot operated clutch pedal situated left of centre mounted brake pedal is permitted.

3.6 BATTERY ISOLATION SWITCH:

- (a) Each Gearbox Superkart shall be equipped with a battery isolation (master) switch which effectively isolates all electrical circuits from the battery and stops the engine.
- (b) 125NGB shall use the standard Rotax wiring loom with an ignition switch.
- (c) Both the GB and NGB switches shall be capable of being operated by the seated Driver and from outside the automobile.
- (d) These switches shall be clearly marked by a symbol showing a red spark in a white-edged blue triangle shown on the bodywork outer surface.
- (e) Control switches for electrically powered devices and accessories must be located forward of the Drivers elbow in the normal seated driving position, and be accessible to trackside officials with the Driver seated.
- (f) The allowable mounting areas are confined to; an area beside the forward part of the seat; the Nassau panel/bubble area; or on the steering wheel.
- (g) Switches may be toggle, slide or push-pull type, and shall be individually identified as to on/off position and function.
- (h) Grouped switches shall be arranged so that all are 'off' and 'on' in the same direction or position.

4. WHEELS AND TYRES

4.1 TYRES:

- (a) Tyres shall be pneumatic, with or without tubes, with a maximum outside diameter of 350mm.
- (b) It is not permitted to use retreaded or remoulded tyres.
- (c) It is not permitted to use hand-grooved tyres.

- (d) It is not permitted to use tyre treatments. It is not permitted to use fluids or other compounds.

4.2 WHEELS:

- (a) All wheels shall revolve on ball or roller type bearings, either as separately mounted wheels or on a rotating axle shaft.
- (b) Cast iron and plastic wheels are forbidden. Wheels must be secured to their axles by either high tensile bolts or self-locking nuts.
- (c) For karts of the 250cc Gearbox class (refer section 9.3), the attachment of wheels to hubs must be by stud and self-locking nut fixing, or single hub-nut and locking clip. This method is recommended for other classes.

4.3 VALVE CAPS:

All tyre/wheels must use metal valve caps at all times. These caps used must be sufficient design to maintain tyre integrity in case of valve mechanism failure.

5. BRAKES

5.1 BRAKES:

Brakes must be foot operated and provide efficient braking to at least the two rear wheels. Where there is free play at the ends of the axle keys a hose clamp or other positive mechanical method of key retention is required.

- (a) All exposed brake pad mounting bolts must be drilled and lock wired.
- (b) Dual circuit brakes on all four wheels are compulsory for all Gearbox class karts (refer section 9.3).
- (c) Brake cables, of multi-strand steel wire, must be of at least 2.25mm diameter.
 - (i) Cables must be fastened by a machine swage or by positive clamps which do not cut into the cable.
 - (ii) Clamps must contact both main strand and return strand in two places at each end. Electrical connectors or similar devices are not permitted.
- (d) Brake rods must be of at least 6mm diameter, of solid steel. It is recommended that a secondary actuating method be securely fitted which shall operate the brake master cylinder/s in the event of the detachment or ailure of the primary link component/s fitted between the pedal assembly and the brake master cylinder/s assembly.
- (e) Brake hoses, lines and fittings are to be of suitable pressure line materials designed specifically for hydraulic use.
 - (i) Brake lines shall be connected to components and fittings using male type supporting connections.
 - (ii) The use of female type compression olive fittings alone is prohibited.
- (f) Brake caliper and master cylinder mounting bolts must be of high-tensile steel, and must be drilled and lock wired, or be secured by self locking nuts.
- (g) The use of carbon fibre disc rotors in Superkart racing is prohibited

6. ENGINE

6.1 ENGINES

Engines must be of two-stroke or four-stroke cycle only as detailed in section 9. Modifications are permitted.

6.2 The following classes shall be observed for all Superkart events:

125cc	Gearbox	250cc/450cc	Gearbox National
125cc	Stock Honda Gearbox		

125cc	Non-Gearbox - Light - Heavy	250cc	Gearbox International
125cc	Non-Gearbox Junior		

- (a) A 5% tolerance on swept volume, calculated on the designated class capacity, shall apply to engines with cast iron bore cylinders.
- (b) Engines manufactured with plated cylinders, eg, Nikasil, chrome etc, shall have a bore diameter not exceeding the original standard specifications for that make/brand, type and model engine.
- (c) Re-building and re-plating of damaged plated cylinders is permitted, provided that the original specifications are adhered to. Plated bore cylinders are not permitted to be re-sleeved to take advantage of this tolerance.

6.3 SUPERCHARGING:

Supercharging of engines is forbidden.

6.4 COOLING:

All karts, if not fitted with a sealed cooling system, must be fitted with a catch tank of at least 250ml capacity for karts up to 125cc and 500ml capacity for those over 125cc to retain radiator overflow.

- (a) Glycol-based coolants are prohibited.
- (b) Radiators must not be placed in front of the pedals or behind the rear bumper.
- (c) Radiator caps shall be lock wired or pinned to prevent removal during racing. Radiators fitted with screw-on type caps are exempt.

6.5 EXHAUST:

The exhaust system shall discharge towards the rear and away from the Driver and the exhaust outlet shall not exceed 500mm in height. The exit must not include sharp edges. The outlet of the muffler must be within the perimeter of the kart when viewed from above.

The complete exhaust system must be securely fastened to the kart so as to ensure that it cannot fall should a mounting fail.

6.6 MUFFLERS:

All karts must be fitted with mufflers. The maximum emitted sound is 95dB(A), measured at 30m from the track edge. The Driver, seated normally, must be protected from all contact with the exhaust system.

7. TRANSMISSION

7.1 TRANSMISSION TYPES:

- (a) Front wheel drive systems are forbidden.
- (b) Clutches are compulsory.
- (c) All gearbox drain plugs must be lock wired and all other drain, indent plunger caps and filler caps must be wired.
- (d) Engine sprocket and chain guards are compulsory and must effectively cover the engine sprocket and the axle sprocket down to the centre line of the axle sprocket.
- (e) All chain guards must be securely attached to the kart at both ends.
- (f) All automatic methods of chain oiling and greasing are prohibited.
- (g) Gearboxes must be fitted with a breather pipe which discharges into an overflow bottle of at least 250ml capacity. Any discharge must be contained, and not fall on to the track.
- (h) Where the Driver and other persons or their clothing may come into contact with a moving component that forms part of the engine or transmission, a guard must be fitted to prevent such contact occurring.

8. FUEL

8.1 FUEL TYPES:

- (a) Only fuels as defined by Motorsport Australia Manual Schedule G (refer "General Requirements for Cars and Drivers" in the Motorsport Australia Manual) shall be used. Specific fuel requirements for 125cc Rotax Max Non-Gearbox, 250cc International / 250cc National / 125cc Gearbox and 125cc Stock Honda Gearbox Classes are listed below:
- (b) **125cc Rotax Max Non-Gearbox Classes:**

The 125cc Rotax Max Non-Gearbox Class is permitted to use the following fuel types:

 - (i) "Pump Fuel" as defined by Motorsport Australia Schedule G (2.1)
- (c) **250cc International / 250cc National / 125cc Gearbox Classes:**

The 250cc International / 250cc National / 125cc Gearbox Classes are permitted to use the following fuel types:

 - (i) "Pump Fuel" as defined by Motorsport Australia Schedule G (2.1)
 - (ii) "Racing Fuel" as defined by Motorsport Australia Schedule G (3)
 - (iii) Approved Fuel as defined by the below list:
 - (A) VP Racing Fuels CR99
 - (B) PowerPlus 100+
- (d) **125cc Stock Honda Gearbox Class:**

The 125cc Stock Honda Gearbox Class is permitted to use the following fuel types:

 - (i) "Pump Fuel" as defined by Motorsport Australia Schedule G (2.1)
 - (ii) Approved Fuel as defined by the below list:
 - (A) VP Racing Fuels CR99
 - (B) PowerPlus 100+
- (e) The mixing together of pump fuels, or leaded and pump fuels, is not permitted.
- (f) It is permitted to add to the commercially-available two-stroke oil lubricants that produce two-stroke fuel within the provisions of Schedule G.
- (g) Additives not described as such upon proprietary fixed labelling are specifically prohibited, and any performance boosters incorporated in the two-stroke oil is deemed to be illegal under the rules governing commercially-available fuel.

8.2 FUEL TANK:

- (a) Each fuel tank shall be firmly fixed to the chassis or the floor tray and not by any temporary system of attachment.
- (b) It shall be constructed in such a way that neither it nor any fuel pipes, which shall be flexible, present any danger of leakage during the competition.
- (c) The tank shall be fitted with a male connector to accept the fuel line, which shall be wired or clipped.
- (d) In each Superkart, the side-mounting of a fuel tank shall not be permitted and it is mandatory to install the fuel tank between each main tube of the chassis-frame, ahead of the seat and behind the rotation axis of each front wheel, in accordance with the following conditions.
 - (i) A centrally located fuel tank shall be fitted as above to:
 - (A) each kart log booked after 1 January 2013, and
 - (B) to each other kart prior to its first competition following 1 January 2014.
- (e) Fuel shall be delivered from the fuel tank to the fuel pump only by gravity and/or by atmospheric pressure.
- (f) The tank may be constructed of any leakproof material. Each steel tank shall be manufactured from sheet minimum 0.7mm thick.
- (g) Flame-retardant material is recommended. Maximum capacity of any fuel tank: 18 litres.

- (h) Taps are optional. If fitted, they must be within easy reach of the Driver when seated in the kart.
- (i) Each tank and each fitting shall not project beneath the floor pan.

9. SPECIFIC REGULATIONS FOR CLASSES

9.1 GEAR BOX - 125CC, AND 250CC/450CC:

- (a) These classes shall be open to karts fitted with two-stroke engines (or, in the case of 250/450cc National Karts, four-stroke engines).
- (b) Permitted engines are identified as being the OEM engine cases that carry an indented, stamped manufacturer's or owner's identification code or number and are subject to one of the following:
 - (i) being normally fitted to production motorcycles;
 - (ii) previously and/or currently homologated for use in karting by the FIA or CIK;
 - (iii) approved for use by the Australian Motor Race Commission.
- (c) Modifications are allowed, subject to the general specifications complying with the Motorsport Australia Superkart Technical Regulations.

9.2 125CC GEARBOX CLASS (UP TO 125CC):

- (a) In addition to Regulation 9.1 above:
 - (i) not more than two cylinders per kart.
 - (ii) not more than seven forward gears.
- (b) Brakes must be fitted to both front wheels, as well as to the rear wheels. Karts must be equipped with a double circuit braking system so arranged that the pedal normally operates on the four wheels and in the event of the leakage at any point in the braking system, the pedal shall still control two wheels on the same axle.

9.3 250CC GEARBOX CLASSES (UP TO 250CC FOR TWO-STROKE ENGINES, OR UP TO 450CC WHERE FOUR-STROKE ENGINES ARE PERMITTED):

In addition to Regulation 9.1 above:

- (a) International:
 - (i) two cylinders maximum per machine
 - (ii) two single-cylinder 125cc Gearbox engines are permitted.
 - (iii) Rotax 256 engines may be fitted with approved replacement 'SAFE' engine cases and parts.
- (b) National:
 - (i) 250cc two-stroke single-cylinder per machine
 - (ii) 450cc four-stroke single-cylinder per machine
 - (iii) 450cc four-stroke engine:
- (c) Four-stroke series production single-cylinder engine up to a maximum of 450cc.

The list of eligible engines is as follows:

MAKE	MODEL
Honda	CRF450
Husgvarna	SM450
KTM	SXF450
	SMR450
Kawasaki	KX450F
Suzuki	RMZ450
MAKE	MODEL
TM	MX450F
	SMX450
Yamaha	YZ450F
Rotax	DS450efi
Husaberg	FE450

(d) 450cc four-stroke regulations:

Modifications to the engine are allowed, provided the following are not varied.

- (i) Stroke
- (ii) Bore(outside Maximum Limits)
- (iii) Connecting rod centre line (magnetic material only)
- (iv) Ignition must remain OEM
- (v) Gearbox must retain the same amount of gears as OEM manufactured for the specified model at time of manufacture. (Fuel pulse pump or electric fuel pump is permitted for carbureted engine).
- (vi) Number of carburettors or throttle bodies (one (1) only).
- (vii) Fuel injection is permitted but only if OEM; ie, if fitted as standard to the original motor type, it is permitted to upgrade motors and fit injection, provided the latest version of that model has injection fitted OEM. All upgrade parts must come from the manufacturer's parts list.
- (viii) All systems of injection and/or spraying of products other than permitted fuel are forbidden. It is not permitted to have an electronic connection to the carburettor unless this was standard OEM. It is not permitted to have an electric connection to the carburettor unless this was standard OEM.
- (ix) brakes must be fitted to both front wheels, as well as to the rear wheels. Karts shall be equipped with a double circuit braking system so arranged that the pedal normally operates on the four road wheels and in the event of leakage at any point in the braking system, the pedal shall still control two wheels on the same axle.
- (x) all road wheels must have at least three bead retaining pegs, or bead retention lips, on both the inside and outside rims. Rear wheels must have a total of six retaining pegs, ie, three inside and three outside per wheel. Penalty for non-compliance: exclusion from the event.
- (xi) It is compulsory for dry slick tyres and wet weather tyres used on 250cc Gearbox class Superkarts (refer section 9.3) to be:
 - (A) fitted to 6" diameter rims;
 - (B) homologation by the FIA/CIK;
 - (C) comply with the FIA/CIK regulations for Superkart (Group I - Division 1 and 2);

- (D) bear the “CIK” or “CIK/SK ICE” marking.
- (E) Alternatively, tyres for 6” diameter rims approved by Motorsport Australia and listed in these regulations are eligible for use.

250cc/450cc Motorsport Australia - Approved Tyre		
Dry	6” Hoosier	R60 R60A R60B
	6” Dunlop	DEM-DAU

9.4 125CC NON-GEARBOX CLASS

Chassis, running gear and coachwork:

- (a) Brakes: Must consist of a single disc and caliper acting on the rear axle. Front wheel brakes are prohibited.
- (b) Tyres & Wheels: All wheel rims must be 5” diameter.
- (c) Tyres must be selected from:
 - (i) DRY:
 - (A) Dunlop DGM / DFM
 - (B) Maxxis HG3
 - (C) MG AZRed
 - (D) MOJO D2
 - (E) Bridgestone YLR Rok
 - (F) Dunlop DFH
 - (G) Hoosier R60B
 - (ii) WET:
 - (A) Free (must be fitted to 5” rims)
 - (B) Wet weather tyres shall be used when a race is declared “Wet” and maybe used at all other times.
 - (C) When used, they maybe any brand of wet weather tyre fitted to a 5” diameter rim is permitted.
- (d) Competitors are restricted to one set of four marked dry and one set of four marked wet weather tyres;
 - (i) (two front and two rear) for the duration of the event except as approved by the scrutineers.
- (e) When tyre marking is appropriate, it shall be carried out by the scrutineers prior to the start of qualifying/racing sessions of the circuit race event.
- (f) Only those tyres may be used for the remainder of the circuit race event, save that one front and/or one rear tyre may be replaced at the scrutineers’ discretion.
- (g) Chassis:
 - (i) Circular section tubing only or maximum of one main rail not round.
 - (ii) Maximum diameter for chassis tubing is 35.5mm (inclusive of paint).
 - (iii) The only stub axle mounting system permissible is as per diagram 1.1. Maximum wheelbase 106cm. Maximum rear axle diameter: 50.0mm.

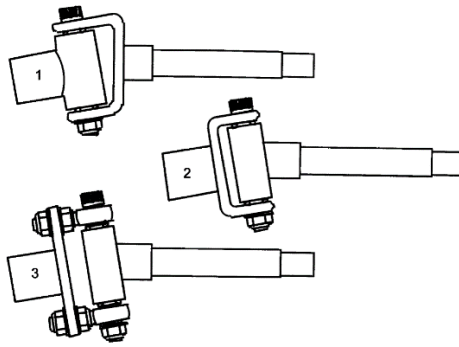

Diagram 1.1 – Stub axle mounting system

Diagrams are for dimensional reference only

9.5 BODYWORK

Bodywork is permitted on 125cc Non-Gearbox Classes. Such body work must respect the following conditions:

- (a) nose cones, bubbles and sidepods, mirrors and numberplate/mounting components are allowed;
- (b) all bodywork, excluding mirrors, forward of a vertical plane, drawn through the centre line of the front wheels in their straight-ahead position and at right angles to the centreline of the kart, must fall within the area of the template described in diagram 9.5.8;

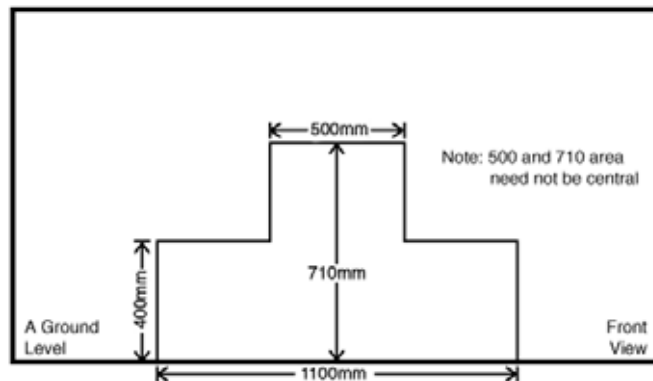

Diagram 9.5.8: Body Template

- (c) no bodywork rearward of this vertical plane shall extend further than 300mm rearward of that plane; be more than 710mm above the ground, be closer than 300mm to the ground, nor wider than 500mm as shown by the template described in diagram 9.5.9.

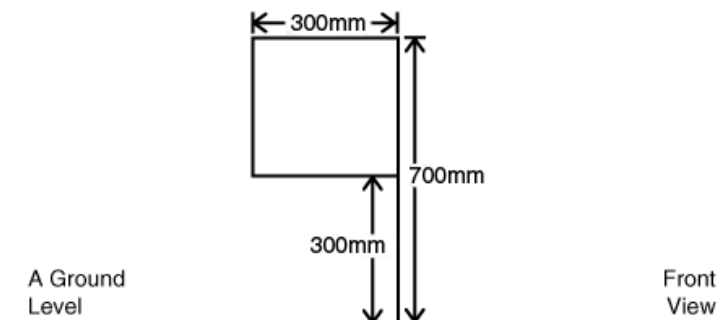

Diagram 9.5.9

- (d) A minimum front fairing / bubble / Nassau panel height is set at 565 measured from the ground to any and all points up to 125mm either side of the centre line of the fairing at the rear of the fairing/bubble/Nassau as to restrict the development of the laydown style chassis.

- (e) the front fairing / bubble / Nassau panel shall not be transparent.

9.6 SIDE PODS

Side Pods are compulsory and must comply with the following compulsory Technical Specifications (refer diagram 9.5.10).

- (a) They must under no circumstances be located either above the plane through the top of the front and rear tyres or beyond the plane through the external part of the front and rear wheels (with the front wheels in the straight ahead position).
- (b) In the case of a "Wet Race", the side pods may be located outside the plane passing through the outer edge of the rear wheels.
- (c) They may not be located inside the vertical plane through the two external edges of the wheels (with the front wheels in the straight ahead position) by more than 40mm.
- (d) They must have a ground clearance of 25mm minimum and of 60mm maximum.
- (e) The surface of the side pod must be uniform and smooth; it must not comprise holes or cuttings other than those necessary for their attachment.
- (f) Gap between the front of the side pod and the front wheel: 150mm maximum.
- (g) Gap between the back of the side pod and the rear wheel: 60mm maximum.
- (h) No part of the side pods may cover any part of the Driver seated in their normal driving position.
- (i) The side pods must not overlap the chassis-frame seen from the underneath.
- (j) On the outer side they must comprise a vertical surface (with a tolerance of $\pm 5^\circ$ in relation to the theoretical vertical plane) with a minimum height of 100mm and a minimum length of 400mm located immediately above the ground clearance.
- (k) They must not be able to hold back water, gravel or any other substance.
- (l) They must be solidly attached to the side bumpers.
- (m) Materials: side pods shall be made of non-splinterable plastic, or fibreglass.
- (n) Composite materials, carbon fibre and Kevlar are prohibited.

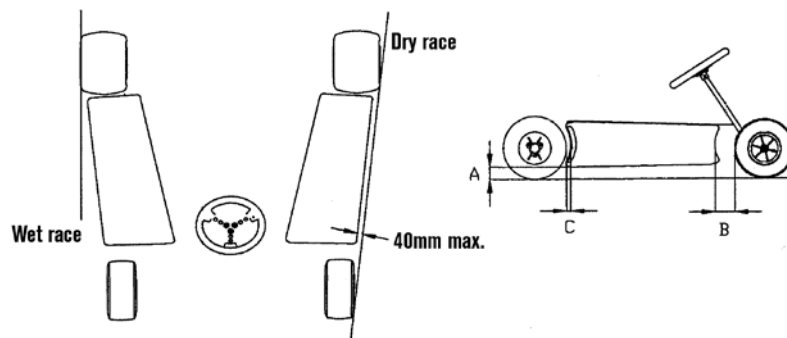

Diagram 9.5.10

A – 25mm minimum to 60mm maximum

B – 150mm maximum

C – 60 mm maximum

9.7 Floor Tray

Each kart must be fitted with a flat floor tray, made of rigid material which extends from the front of the seat to the front of the kart only, which covers the whole width of the kart between the outer edges of the main longitudinal frame rails and which is no wider at any point than the longitudinal frame rails;

- (a) each kart shall be fitted with a minimum of three number plates, each not exceeding 300mm x 300mm and otherwise complying with the requirements of Superkarts – Technical Regulations Article 2.4.

- (b) Rear side plates are only permitted if used to carry the number plate and must be no larger in width or height than necessary to carry the required numbers.

9.8 Composite materials:

Composite materials are not permitted save for the construction of seats, fairings, bubbles, chain guards, number plates, rear side plates, mirror housings and the floor tray.

9.9 Steering:

Steering: Must comply with Superkarts - Technical Regulations, Article 3.4.

9.10 Drivesprockets:

Drivesprockets are free.

9.11 Battery:

The battery leads must be removable without recourse to tools unless the kart is fitted with the MAX EVO battery box with integrated ignition and starter switch.

The battery must be securely attached directly or indirectly to the chassis using self-locking nuts and bolts/threaded metal rods.

9.12 Tail Lights:

Tail lights must comply with Superkarts - Technical Regulations Article 2.8.

9.13 Engine:

(a) The only engine permitted is the BRP Rotax FR125 Max and FR125 Max EVO. The Senior Max Engine, ~~"125 Max EVO" product number 125 MAX/35.0125.140~~ is for Senior Classes use only.

(b) The Junior Max engine, ~~"125 JUNIOR Max EVO" product number 125 Junior MAX/35.0125.130~~ is for Junior Classes use only.

(c) ~~Unless expressly permitted under these regulations, all engine and driveline parts must be of Original Equipment Manufacture (OEM) by BRP Rotax GmbH.~~

The engine must always be used and presented in strict conformity with the specifications detailed in the relevant homologation documents. Unless specifically permitted by these regulations, only Rotax OEM parts that have been manufactured and/or supplied by Rotax GmbH for the engine are permitted to be used in the engine at any time.

Neither the engine nor any of its ancillary components may be modified other than in accordance with the rules and the relevant homologation documents.

(d) Non-technical items are

- (i) battery
- (ii) fuel filter
- (iii) radiator hoses
- (iv) clamps
- (v) pulse line
- (vi) switches
- (vii) ancillary mounts
- (viii) fasteners
- (ix) circlips
- (x) washers
- (xi) bearings
- (xii) spark plug
- (xiii) gaskets
- (xiv) O-rings
- (xv) piston pin

- (xvi) springs
 - (xvii) seals
 - (xviii) clutch drum
 - (xix) engine sprocket
 - (xx) rings
 - (xxi) starter motor and clutch flywheel
- (e) No alteration from the original manufacturer's specification is permitted to fit a non-technical item.

9.14 Cylinder Heads:

Cylinder head capacity:

- (a) Shall be a minimum of 11.0cc using the method detailed in the Superkarts - Technical Regulations, Article 9.15.
- (b) (Displacement: 125.0cc maximum.
- (c) Combustion chamber insert:
 - (i) Only Rotax genuine part ~~number 223 389 or 223 389 1 or 223 389 2~~ may be used. The name Rotax or 'made in Austria' must be cast into the combustion chamber insert. No additional material may be added except to repair the spark plug thread and or spark plug sealing surface.
 - (ii) All machined surfaces may be re-machined. The insert must retain both squish band and spherical combustion chamber. An 'O-ring' must be fitted.
 - (iii) Minimum squish clearance of 1.0mm to 1.5mm for senior Max engines and 1.2mm to 1.8mm for junior Max engines, measured using 2mm solder or tin wire. The average of the two measurements taken from the left and right sides of the bore will be taken as the actual measurement for an engine.
- (d) Spark plug thread length: The maximum spark plug thread length is 20mm.
- (e) Piston: Only pistons which are OEM and comply with the following regulations may be used:
 - (i) Coated or uncoated, aluminium, cast piston with one and only one 1.0mm rectangular piston ring.
 - (ii) The piston has to show on the inside the words "ELKO and "Made in Austria" in the casting.
 - (iii) Machined areas are: top crown of piston, outside diameter, one groove for the piston ring, bore for gudgeon pin, inside diameter at bottom end of piston. No other surfaces are machined.
- (f) **Gudgeon pin:**

Gudgeon pins which comply with the following measurements may be used and must be made of magnetic steel:

Length	45.6mm max ± 0.45mm
External Diameter	15.0mm -0.003mm
Internal Diameter	10.0mm max +0.1 -0.2mm

- (g) **Cylinder:**
 - (i) Only cylinders supplied by Rotax and complying with the following regulations may be used.
 - (ii) Lightalloy cylinder with Gilnisil plating. Replating is permitted.

Maximum Bore	54.035mm (measured 10mm above exhaust port)
---------------------	---

- (iii) ~~Cylinder must be marked with Rotax logo. Cylinder base must be marked with manufacturer's identification code: 223 997 or 223 996 or 223 993.~~ Machining of this cylinder is not permitted. No additional machining of ports or passages.
- (iv) Cylinder must have official Formula Rotax Australia stamp on the inlet face.
- (v) Junior class to use only cylinder without exhaust power valve.
- (vi) Cylinder has to be marked with ROTAX logo and identification code: ~~223 999 or 223 998 or 223 994.~~

Length of cylinder	87mm with +0.1 / -0.05mm tolerance
---------------------------	------------------------------------

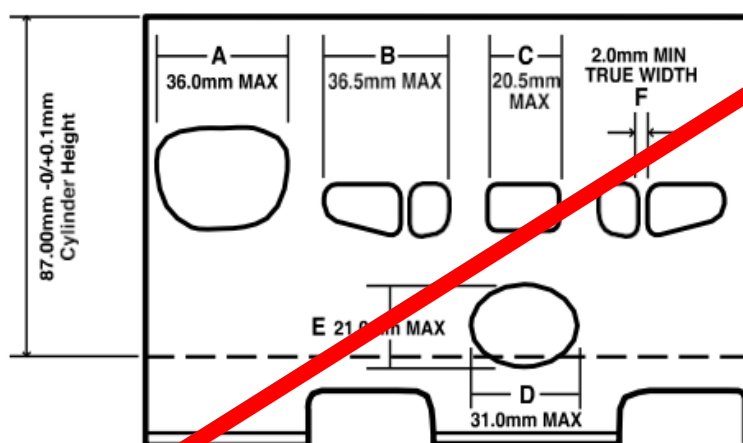

~~Diagram 9.6.1: Flat Port Development FR-125 Junior Max
Diagrams are for dimensional reference only~~

- (h) **Cylinder base gasket/s:** Must be dimensionally the same size and shape as original equipment and shall not have the effect of decreasing the size of the transfer ports.
- (i) **Inlet system:** No material may be added and no grinding or machining is permitted to any part of the inlet system including the manifold and reed valve assembly.
 - (i) The manifold must carry the manufacturers name ROTAX and identification code: ~~267 945.~~
 - (ii) The reed valve assembly must carry the manufacturer's name ROTAX and identification code: ~~224 387 or 224 389.~~
 - (iii) The reed valve assembly must be equipped with two petal stops and two reeds, each having three petals

Thickness of reeds	0.6mm +/- 0.08mm
Reed block gasket/ spacer thickness	4.0mm max.

- (iv) The addition of one Rotax reed block gasket, maximum of 1.0mm thick, between the carburettor manifold and the reed block is permitted.
- (j) **Exhaust power valve:** No modifications are permitted to the exhaust power valve. The original spring must be fitted. No external adjustment or blocking to this device whilst the engine is running is permitted.

- (i) External control of the powervalve by the RAVE Control Unit (~~Part Number 893-870~~) is permitted, no other modification to the Control Unit are permitted. Maximum thickness of powervalve gasket/s is 2.0mm.
 - (ii) Additional fasteners or securing devices may be fitted/added. The length of the exhaust valve is 36.5mm +0.2/-0.3mm. Collar width is 4.8mm +/- 0.3mm. ~~Exhaust Valve Evolution is approved part ID253-725 or 484-265.~~
- (k) **Crankshaft:** No modifications are permitted to the crankshaft.

Stroke	54.5mm +/- 0.02mm.
---------------	--------------------

- (l) **Balance shaft:** No modifications are permitted to the balance shaft, which must be installed and operational.
- (i) ~~The balance shaft shall be either part number/type 237-945, 237-948 or 237-949.~~
 - (ii) The minimum weight of the dry balance shaft is 355 grams for part number/type 237-945 and 255 grams for part number/type 237-948 and 237-949.
 - (iii) Both the plastic balance gears, ~~part number 234-431,~~ or the steel balance gears, ~~part number 234-436,~~ are permitted. Balance gears must be installed and correctly aligned according to the instructions in the repair manual.
- (m) **Connecting rod:** No grinding /polishing or modifications are permitted.
- (i) Connecting rod must bear the manufacturer's stamp of ~~"213" or "365", "367" or "362"~~ on the shaft.
- (n) **Crankcase:** The two main transfer passages of the crankcase must remain untouched as supplied.
- (i) The official Formula Rotax Australia stamp must be on the crankcase deck.
- (o) **Ignition unit:** The ignition unit must be DENSO or Dellorto digital ignition systems only, with no adjustment permitted or possible.
- (i) Two versions of spark plug caps are legal to be used:

Spark plug cap	Black, marked with "NGK TB05EMA
Spark plug cap	Red, marked "NGK" or un-marked OEM

- (ii) Dellorto ignition coil must be part number 666-825, Dellorto ECU must be part number 666-814 or 666-815 for the Senior Max engine and 666-812 or 666-813 for the Junior Max engine. No modification to any part of the ignition system and/or crankshaft to alter the ignition timing or rev limiter is permitted.
 - (iii) The DENSO ignition coil must have three pins at the terminal.
 - (iv) Battery make is free.
- (p) **Carburettor:** "VHSB34" must be cast in the housing of the carburettor

	Specification 1	Specification 2	EVO Specification
Identification Mark	QD or QS	QD or QS	XS
Needle jet	FN266	FN266	DP267
Needle	K27, K54, K98	8 K27, K54, K98	K57
Slide	#40	#40	#45
Slide Insert	12.5	8.5	12.5
Floats	5.2gm	3.6gm	4.0gm

- (i) All items referred to in the table must be present and operational. Any combination of items in the table above may be fitted.

- (ii) The carburettor body, slide, needle, atomiser tube (needle jet) and atomiser and float arm must remain as originally supplied and may not be modified. No additions or machining, filing, drilling or polishing to these items, including the carburettor bore/throat, is permitted.
 - (iii) No changes or adjustments can be made to the main jet or air bleed screw whilst the engine is running.
 - (iv) The size of any hole in any of the following is unregulated: main jet, needle and seat, pilot jet, pilot emulsion insert, choke jet. The position of the float/float arms and the weight of the floats is unregulated.
 - (v) All other settings in the carburettor are free.
- (q) **Fuel pump:** Only one Mikuni DF44-211-D pulse fuel pump may be used. Fuel must be supplied directly from the pump to the carburettor by an uninterrupted fuel hose connection. The maximum length of the fuel line from the tank to the fuel pump is 1000mm, and from the fuel pump to the carburettor is 500mm.
- (r) **Radiator:** One (1) only, genuine Rotax aluminium radiator is permitted.

Cooling area	Height:	290mm
	Weight:	133mm
	Thickness	32mm

- (i) Any radiator produced by Rotax for the Rotax Max FR125 engine complying with the above dimensions is permitted.
 - (ii) Placement of radiator is free subject to Superkarts - Technical Regulations Article 6.4. Only thermostats supplied for Rotax Max FR125 as OEM by BRP Rotax GmbH may be used.
- (s) **Clutch:** The clutch must be of dry centrifugal type using genuine Rotax components unless nominated as a non-tech item; both genuine Rotax clutches are permitted.
- (i) Whilst on level ground the kart (with Driver) must start to move under its own power, when the engine speed reaches 3000rpm or less.
 - (ii) The use of the Rotax clutch pin support plate is permitted.
 - (iii) Clutch springs are not classed as non-tech items and must be genuine Rotax components. Lubrication of the clutch is prohibited.
- (t) **Intake silencer:** The intake silencer as supplied by Rotax for the FR125 Max must be fitted, with no modifications permitted.
- (i) The air filter must be in place, and be either fine or coarse type 030 filter. The silencer must be fitted with the inlet trumpets at the base of the unit.
 - (ii) It is permissible to drill a single hole up to 8mm in diameter in the lower part of the intake silencer (in the centre of the plastic injection mark). Either type of airbox may be used, comprising casing parts 225 025 and 225 015, or casing parts 225 010 and 225 020, 8mm drain hole is permitted.
- (u) **Exhaust system:** The exhaust system must be as supplied by Rotax for the FR125 Max and may not be modified except for:
- (i) silencer absorption material may be replaced with a genuine part as supplied by Rotax,
 - (ii) addition of a single-sensor probe fitting.
 - (A) Welding for the purposes of repair of cracks, holes or fitting of patches only is permitted. No welding which has the effect of altering the shape of the exhaust system is permitted. Endcap rivets must be replaced with bolts, capscrews etc, suitable for the purpose.
 - (B) Junior class to use only Type B or EVO style exhaust as supplied by ROTAX.
- (v) **Engine Measuring:** Engine measuring procedure for Rotax FR125 Max using official gauges:

The gauges have been designed to make engine measuring quick and easy. If an engine fails when measured with these gauges, the Competitor may request that the engine be re-measured using normal precision measuring tools.

10. STOCK HONDA 125CC GEARBOX SUPERKART

The class shall be known as Stock Honda 125cc Gearbox.

Preamble

The spirit and intent is such that any attempt to elaborate on these Stock Honda regulations in order to gain a competitive advantage violates the basic premise of the class. A modification or tuning practice which is not permitted by the present regulations is expressly forbidden. Compliance is at all times the competitor's responsibility. Superkarts complying with the Stock Honda Regulations shall continue to comply with the 125 Gearbox Regulations at all times, in addition to the following regulations.

(a) Chassis:

- (i) The chassis shall be CIK homologated and which bears the manufacturer's CIK tag intact on the chassis.
- (ii) If the chassis is not currently CIK homologated, documented proof must be presented that the chassis was previously CIK homologated.
- (iii) The main frame rails and cross members shall not be altered.
- (iv) Repairs to the chassis are allowed provided the chassis remains within its approved CIK dimensions.
- (v) In the case of a questionable chassis the manufacturer's signed and approved CIK homologation document will be the definitive authority.

(b) Floor Tray:

- (i) Each kart shall be fitted with a floor tray made of rigid material that covers only from the central cross member of the chassis frame to the front of the chassis frame.
- (ii) It shall be laterally edged by the chassis tubes or a rim to prevent the driver's feet from sliding off the floor tray.
- (iii) It shall not extend beyond outer edges of the main longitudinal frame rails.
- (iv) The floor tray may only have one hole of 35mm maximum diameter solely for the purpose of steering column access and no other holes of greater than 10mm maximum diameter.

(c) Seat:

- (i) Laydown-style seats are not allowed.
- (ii) For CIK sprint-style seats, the seat back and seat bottom shall remain unaltered to original manufacture.
- (iii) Seat bottom may be repaired as required from road wear. No point of the seat back shall extend beyond the rear axle (as per Figure D) and the highest point of the seat back shall measure at least 360mm minimum off the ground measured in a vertical plane.
- (iv) For Superkart-style seats, they shall incorporate a headrest which is "as one" with the seat. The headrest shall not be detachable or adjustable in any form. Seat bottom may be repaired as required from road wear. No point of the seat back shall extend beyond the rear axle including any part of its head rest as per Figure D.

NOTE: It is recommended the seat is positioned so there is enough allowance for the scrutineer to determine all parts of the seat is forward of the rear axle. Any uncertainty in this determination will be deemed non-compliant.

FIGURE D

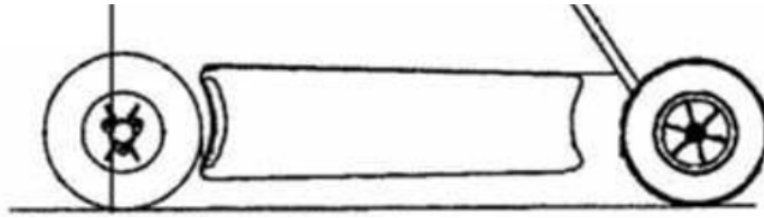

Vertical plane refers to 90 degrees from level ground.

(d) **Bodywork:**

- (i) CIK sprint kart-style plastic nose cone, nassau panel and side pods shall remain unaltered other than necessary for installation of radiator and mounting the side pods.
- (ii) CIK plastic nose and nassau panel may be replaced for fibreglass superkart-styled bodywork. Fibreglass bodywork, excluding mirrors, forward of the vertical plane drawn through the centre line of the front wheels in their straight ahead position must fall within the area of the template described in Figure A.

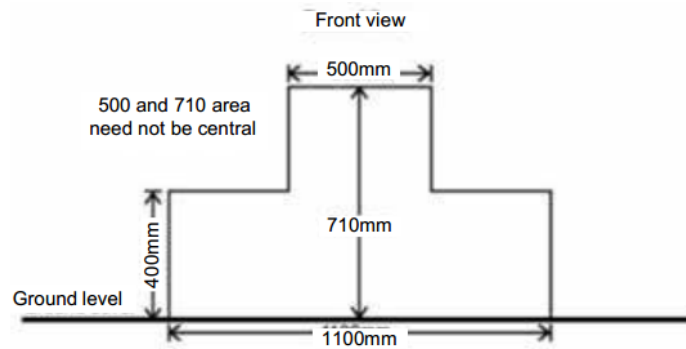

Figure A

- (iii) Fibreglass bodywork rearward of the vertical plane that is drawn through the centre line of the front wheels in their straight ahead position shall fall within the dimensions described in Figure B.

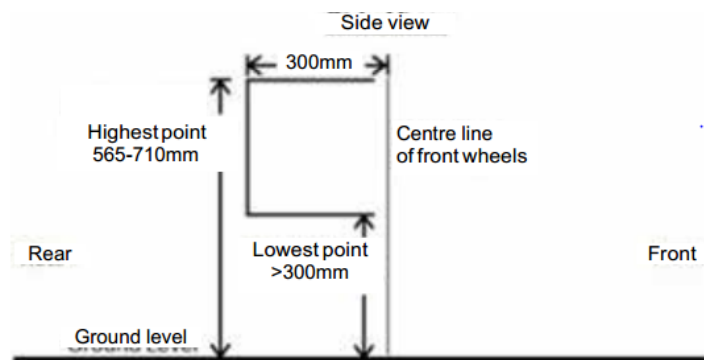

Figure B

(e) **Brakes:**

- (i) The kart shall have a single brake pedal that operates four-wheel braking using two separate braking circuits that governs the front and rear braking independently.
- (ii) A brake caliper shall be fitted for each of the front axles as well as for the rear axle.
- (iii) In the event of leakage at any point in the braking system, the pedal shall still operate braking to either the rear or the front axles.

(f) **Tyres:**

- (i) Any 5" diameter racing kart tyres may be used.
 - (ii) A maximum of three individual front and three individual rear tyres (six tyres total) are allowed per circuit race event, marked by the Chief Scrutineer or their nominee prior to qualifying.
- (g) **Weight:**
- The Stock Honda 125cc Gearbox class shall comply with a minimum combined kart/driver weight of 180kg at parc fermé after the race.
- (h) **Numbers:**
- The Stock Honda 125cc Gearbox class shall observe race numbers in accordance with the Motorsport Australia Manual, Superkarts – Technical Regulations, 2.4 Numbers using “red background” number plates with “yellow race numbers”.
- (i) **Fuel:**
- Only Commercial Fuel or Leaded Racing Fuel as per Schedule G in the current Motorsport Australia Manual shall be used.
- (j) **Cooling System:**
- (i) Radiator is free in size and make.
 - (ii) Only one radiator shall be mounted and shall be located on the left side of the driver’s seat within the kart’s side pod perimeter.
 - (iii) An inline thermostat is allowed.
- (k) **Engine:**
- (i) The procedure for engine measurements is detailed in Appendix 1 to these regulations.
 - (ii) 11.1 The engine shall be the 1999 Honda CR125 – commonly known as 1999 Honda CR125 karting kit motor. Initial identification is by marking of JE01E on the lower left engine casing.
 - (iii) All engine parts shall be of Original Equipment Manufacture (OEM) by Honda and any of its auxiliary components shall not be modified in any way from the original manufacturer’s specification unless expressly noted under these regulations.
 - (iv) Adjustments to components that are specifically designed for that purpose shall not be construed to be a modification (ie, carburettor float level, jets, needles, adjustment screws, spark plugs, etc).
 - (v) The kick starter and its mechanism may be removed and transmission cover plugged.
 - (vi) The engine’s right rear cylinder nut and right side head nut shall be replaced with longer fasteners. These fasteners shall have a minimum 4mm pre-drilled hole to allow ‘event’ engine sealing by the Chief Scrutineer or their nominee. Any competitor may be excluded from taking part in competition until such compliance allowing their engine to be sealed in the above manner.
 - (vii) Non-technical items are the battery, fuel line, fuel filter, radiator, radiator hoses, clamps, ancillary mounts, fasteners, circlips, washers, sprockets, drive chain and cables.
- (l) **Gaskets and Seals:**
- (i) The engine gaskets and seals are non-technical items, except for the cylinder head gasket, cylinder base gasket, exhaust flange base gasket and reed valve manifold gasket as detailed within their subsections.
 - (ii) All seals shall be the same size and diameter as OEM.
- (m) **Crankcase:**
- (i) The crankcases shall be stock 1999-2002 OEM CR125 Honda cast with “JE01E” on the lower rear left side engine case.
 - (ii) A hole shall be drilled and threaded to accommodate the fuel pump pulse line.
 - (iii) The crankcase may be externally “clearanced” around the sprocket area to accept a larger front drive gear. No other machining or modifications allowed to engine cases.
 - (iv) Factory grinding may be present in the transfer area around the main bearing lubrication holes. No polishing or grinding shall be present on the shape of the transfers which must present its original casting pattern.

- (v) 1999-2002 crankcase identification can be determined by the transfer layout in Figure G.

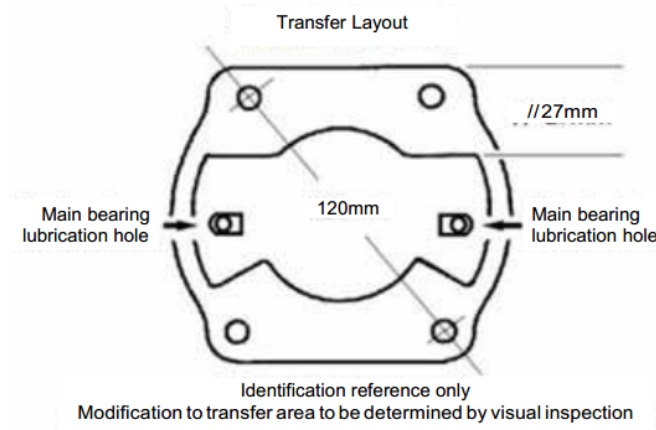

Figure G

(n) **Cylinder:**

- (i) The cylinder shall be a completely stock 1999 OEM CR125 P/N: 12110-KZ4-J10 as cast with no modifications.
- (ii) Exhaust power valve ports shall be plugged.
- (iii) Aftermarket power valve plugs may be modified to achieve desired fit. No machining or grinding to any portion of the exhaust port is permitted. No modifications such as porting or decking is permitted.

Replating of the cylinder is permitted. All replating work must be carried out by L.M. ELECTROPLATING INDUSTRIES PTY LTD (operating as Electrosil in VIC) only; the use of other replating service providers is not permitted.

- (iv) Minor factory grinding of the cylinder walls may be present prior to the original Nikasil process. Any grinding evident after the original Nikasil process is considered a modification.
- (v) Original bore size is 54.00mm; any normal wearing to cylinder above this size is acceptable.
- (vi) Length of cylinder must be 84.15mm +/-0.05mm.
- (vii) The cylinder can be identified by the port layout in Figure E.

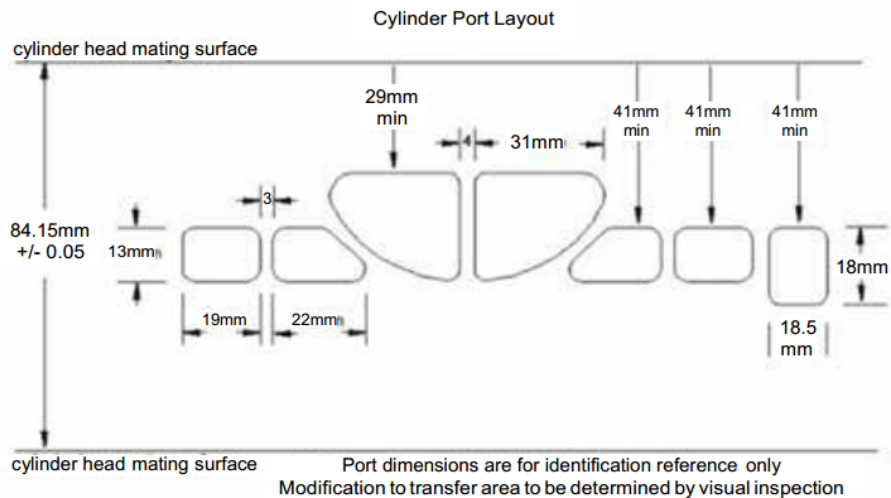

Figure E

- (viii) Cylinder may be spot faced where the four cylinder nuts secure the cylinder to the engine cases.

- (ix) Cylinder base gasket shall be the OEM CR125 P/N: 12191-KZ4-J00 identified as being yellow in colour on one side, tan in colour on the other. Thickness of OEM CR125 base gasket is 0.5mm thick. If so desired, aftermarket base gaskets of varying thickness may be added to the OEM CR125 base gasket to achieve any combined thicknesses above 0.5mm.
- (o) **Cylinder Head:**
- (i) The cylinder head shall be OEM CR125 P/N 12200-KZ4-J00 with no machining or modification to the OEM combustion chamber volume, shape or dimensions whatsoever. The head is identified as cast with markings "KZ4" and either "E-4 or E-3".
- (ii) The combustion chamber profile shall match when checked using the official "Stock Honda" head profile gauge tool. Only one cylinder head gasket can be used and shall be OEM CR125 P/N 12251-KZ4-701, thickness = 0.25mm.
- (p) **Piston Assembly:**
- (i) Only the OEM 1999 CR125 piston assembly shall be used. The OEM piston P/N 13110-KZ4-506, OEM piston ring P/N 13121-KZ4-A91, OEM piston pin P/N 13111-KV3-000 and OEM upper rod bearing P/N 91103-KZ4-B01 shall all remain stock without any modification/s.
- (ii) The piston can be identified as cast with "ART", is of flat top design, and has a window on the inlet side with no lubrication holes for the exhaust bridge. The ring is of 1mm thick design. The design of the piston pin is of 47mm long with an external diameter of 15mm.
- (iii) The design of the upper rod bearing is of 17.15mm wide.
- (q) **Crankshaft:**
- (i) Crankshaft assembly shall be OEM 1999 CR125 P/N 13300-KZ4-B00. No material may be added or removed from the crank wheels or connecting rod.
- (ii) Connecting rod shall be OEM with no modification, lightening or polishing. For identification purposes, the connecting rod is cast with "KZ4A" and ignition side of crank wheel is stamped with "G".
- (iii) All crankshaft assembly components and rod bearing shall be OEM 1999 CR125. The OEM CR125 rotor key shall remain in place with no modification to the key or crankshaft keyway.
- (iv) Slip fitting of crankshaft journals is permitted. Only OEM CR125 P/N 91002-KY4-901 crankshaft main bearings can be used. The bearing journals may be polished for slip fit onto crankshaft.
- (r) **Clutch:**
- (i) Only stock OEM CR125 clutch basket P/N 22100-KZ4-700, clutch centre P/N 22120-KS6-010 and pressure plate P/N 22351-KS6-000 and shall be used as manufactured. All seven OEM clutch friction disks P/N 22201-KS6-700 and all six clutch plates P/N 22321-KA3- 710 shall be installed.
- (ii) No modifications allowed to any component.
- (s) **Transmission:**
- (i) Only six-speed transmission is allowed, all components shall be of OEMCR125. Transmission bearings shall be steel material only. Polishing of gears is not allowed. Ratios of the six gears are as follows:
- | | | |
|---------------|-------|-------|
| First | 14/33 | 2.357 |
| Second | 15/28 | 1.863 |
| Third | 19/29 | 1.526 |
| Fourth | 21/27 | 1.286 |
| Fifth | 23/26 | 1.130 |
| Sixth | 24/24 | 1.000 |
- (ii) The primary drive gear attached to the crankshaft is a 20-tooth gear and the primary driven gear incorporated as part of the OEM 1999 CR125 clutch basket is a 63-tooth gear.
- (t) **Water Pump:**

Water pump shall be OEM 1999 CR125 and used to circulate water as intended. No modifications to impeller or housing of any kind. No external or axle driven water pumps are allowed.

(u) **Air Filter:**

The carburettor shall be equipped with a purpose air cleaner/filter of choice.

(v) **Carburettor:**

- (i) Only a stock Keihin 38mm PWM carburettor shall be used. Carburettor is cast with PWM on its body. No polishing, grinding, machining or modification to any internal passages. No additional internal or external performance modifications allowed.
- (ii) The maximum standard carburettor bore measurement will be determined at the engine side of the slide.
- (iii) Control point for measuring purposes is the first 10mm of the Venturi diameter downstream from the slide. This 10mm wide zone shall not exceed 38.6mm in diameter.

(w) **Carburettor Boot:**

The carburettor boot shall be OEM CR125 P/N 16221-KZ4-A10 and not be modified. This 30 degree boot shall be identified as marked with "KZ4M".

(x) **Reed Valve:**

- (i) Reed cage shall be stock OEM CR125 P/N 14100-KZ4-J11 of six-petal design. No material shall be added or removed from the reed cage.
- (ii) Reed stops shall be as per 1999 OEM CR125. Bending the stops to fit into an unaltered reed throat of crankcase is allowed. Removal of material from reed stops is not allowed.
- (iii) The reed valve layout can be identified using Figure F.

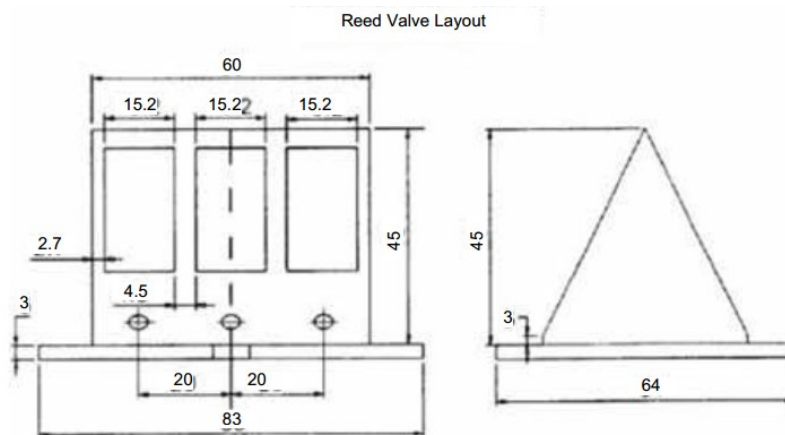

Figure F

- (iv) For longevity reasons, aftermarket replacement reed petals are allowed, including mono reeds and stiffeners. This allows reed petals to be fitted to the unaltered OEM CR125 P/N 14100-KZ4-J11 reed cage.
- (v) A reed valve manifold gasket must be used and it shall only be 1x OEM CR125 P/N 14132-KZ4-620 identified as being yellow in colour on one side, tan in colour on the other. Thickness of reed valve manifold gasket is 1mm thick +/- 0.1mm.

(y) **Fuel Pump:**

Only the Mikuni DF52 series (round type, 35 litres/hour) or Dellorto P34 PB2 P/N: D11023 (55 litres/hour) fuel pump allowed. No pump around system is allowed. Fuel Pump shall be driven by pulse pressure in the motor.

(z) **CDI:**

- (i) The Capacitive Discharge Ignition (CDI) shall be stock OEM 1999 CR125 P/N 30410-KZ4-J11 that displays Denso Part Number "071000-1410 KZ4R" on the box. Race officials reserve the right for competitors to randomly swap CDI's prior to racing.

- (ii) CDI's are to be marked with competitor's name and returned to rightful owner on completion of the circuit race event.
- (aa) **Ignition Coil:**
- The ignition coil shall be stock OEM CR125 P/N 30500-GY8-901 which is marked with GY8 1G3961 on its body. The HT coil wire is free; the spark plug cap shall be NGK TB05EMA.
- (bb) **Spark Plug:**
- (i) The spark plug manufacturer is open but shall be commercially available.
 - (ii) The maximum spark plug thread length is 20mm; thread size M14 x 1.25 pitch. The spark plug washer shall not be removed. The gap of the electrode may be adjusted.
- (cc) **Generator and Flywheel:**
- (i) The generator and flywheel assembly shall be stock OEM CR125 P/N 31100-KZ4-J11. The flywheel shall contain the factory identification marks "KZ4R 03200-9360".
 - (ii) The flywheel and crank key shall remain in place as originally indented with no modifications.
 - (iii) The lower right side of the stator base plate shall contain factory marking "KZ4R". The stator plate shall not have any modifications. The left-hand lower limiting plate on the stator shall have the SKUSA timing plate installed.
 - (iv) Any attempt to exceed the SKUSA timing plate adjustment amount is not permitted. No modifications allowed to the stator plate hold down bolts or the SKUSA plate. No other modification to any other ignition components that changes the static timing beyond what the SKUSA plate allows/ intends.
- (dd) **Ignition Harness:**
- (i) No additional components shall be electrically connected to the CDI or Coil. Only an inductive RPM sensor/wire for tacho readout shall be used.
 - (ii) The engine harness "kill switch" wires may be lengthened to facilitate mounting of the engine kill switch.
 - (iii) Engine kill switch shall only be of toggle action and function to completely stop the engine. The use of a momentary action or push button engine kill switch is expressly forbidden.
 - (iv) The mounting of any push button switch within the kart will result in circuit race event disqualification.
 - (v) All other ignition harness wires and connectors shall remain original OEM without any modification except in case of repair to the coil spade connector or coil grounding ring. These repairs shall only be made identically purposed as originally intended.
- (ee) **Exhaust:**
- (i) The exhaust pipe chamber shall only be the RLV R4 (Part # 6830) without modification, using either the RLV silencer 1" inlet x 12" body length or the M4 silencer 1" inlet x 12" body length.
 - (ii) No dimensional modification allowed to either silencer however repacking of silencer is allowed as required. The addition of an exhaust gas temperature sensor is allowed to the exhaust pipe but the hole shall be plugged if exhaust temperature sensor is not used.
- (ff) **Exhaust Flange:**
- (i) Exhaust flange is open to allow the use of an aftermarket oring flange for greater convenience and sealing of the exhaust system. Any aftermarket flange shall meet the OEM 1999 CR125 exhaust flange dimensions for the opening and overall length as per Figure C.
 - (ii) No spacers shall be used to adjust exhaust flange length when fitted to the cylinder. No pipe spacers shall be slipped in the pipe or over the exhaust flange.
 - (iii) The exhaust length shall not be adjustable by any means when the exhaust pipe is fitted to the flange.
 - (iv) If an exhaust flange base gasket is used, it shall only be one gasket of OEM CR125 P/N 18291-KZ4-700. Aftermarket exhaust flanges that incorporate oring sealing design to its base is acceptable.

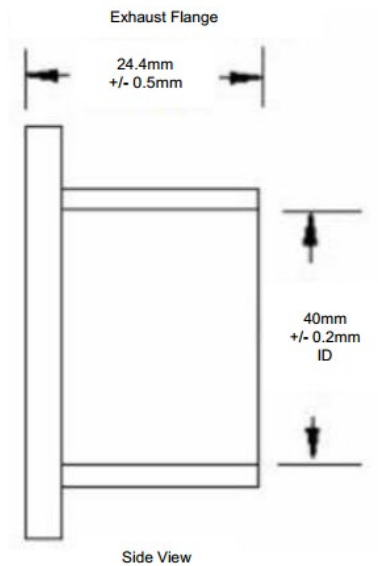

Figure C

(gg) **Starter Motor:**

- (i) An on-board starter motor that serves purpose to only start the engine may be fitted. Starter motors approved for Stock Honda 125cc Gearbox class;
- (ii) Hegar 4 Quick Start for Honda CR125.
- (iii) No modifications allowed to HEGAR 4 drive cup or electric starter motor.
- (iv) The HEGAR 4 starter motor is identified by having “HEGAR4.COM” machined into its mounting body. **Note:** Competitors should be aware that to comply with article 30 of these regulations, the starter motor must be activated by a toggle switch and not a push-button switch.

Appendix A – Engine Measuring Procedure and Specifications

10.2 Piston Squish Height:

Rotate the flywheel to bring the piston close but not at Top Dead Centre. Insert 1.5mm thick solder through spark plug opening making sure that the solder reaches the cylinder wall above one side of the piston pin. Roll engine over top dead centre and measure the flattened part of the solder. Using calipers, the squish height shall be greater than 1.27mm using the 1.5mm thick solder.

If the squish is less than 1.27mm, perform this step again to confirm. If the squish is still less than 1.27mm, this suggests that the engine does not conform to these regulations. Further inspection in engine measuring procedure shall determine the cause/s.

10.3 Combustion Chamber Profile:

Remove the cylinder head. Using the supplied Official Stock Honda Australia 1999 CR125 Combustion Chamber Profile Gauge, inspect parabola of chamber dome and squish recess for apparent gaps.

The profile gauge shall match the cylinder head profile. Competitor may clean off carbon build up with abrasive pad if required. The spark plug portion of the profile gauge stem shall not protrude above the spark plug-sealing surface.



10.4 Cylinder Head Gasket:

Remove and measure the thickness of the cylinder head gasket using calipers. It shall be black in colour and of tin construction to measure a thickness of 0.25mm +/- 0.0025mm, OEM only.

10.5 Cylinder Length:

Remove the cylinder from the engine cases. Measure distance between the top and bottom of the cylinder's machined surfaces using calipers. The cylinder length shall measure 84.10 minimum to 84.20 maximum, with no modifications.

10.6 Port Inspection:

If ports appear substantially different to the cylinder port layout in Figure E, the Technical Inspector should follow up with a close inspection for any evidence of grinding to the port sizes.

Any disqualification should be based on obvious evidence of modification to the cylinder. There must be no replating of cylinder evident for any reason.

Port Height to Cylinder Top:

Exhaust Ports - Minimum Distance > 29mm

The 1999 CR125 exhaust ports have a height that is controlled by the machined operation of the exhaust valve which is very accurate in controlling port location.

Using the supplied Official Stock Honda Australia 1999 CR125 Port Height Check Gauge, insert the Exhaust side (29mm) onto the cylinder top surface in line with the exhaust port. Inspecting through the base of the cylinder, the gauge end shall not extend into the edge of the Exhaust Port opening. Check both ports at their highest points.

Note: Exhaust valves are plugged and these plugs are a non-tech item. Plugs may be ground and shaped to blend the flow along the exhaust passage. All modifications to plug must be done prior to installation within cylinder. The inspection shall not indicate any grinding to the cylinder.

Inlet Ports - Minimum Distance > 41mm

Using the supplied Official Stock Honda Australia 1999 CR125 Port Height Check Gauge, insert the Inlet side (41mm) onto the cylinder top surface in line with an Inlet port. Inspecting through the base of the cylinder, the gauge end shall not extend into the edge of the Inlet Port opening. Check all Inlet ports at their highest points.

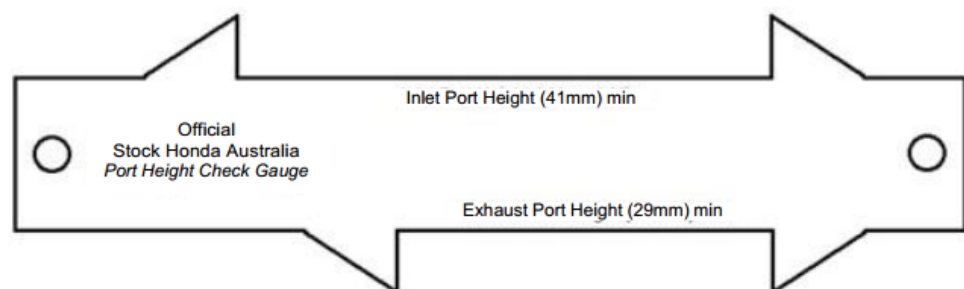

1.1 Piston Inspection and Dimensions:

Only the OEM 1999 CR125 piston can be used and cannot be replaced for any other piston. This piston can be identified as cast with "ART" on the inside skirt, is of flat top design, and has a window on the inlet side with no lubrication holes for the exhaust bridge.

Slide piston pin out of piston with no more than 6mm protruding. Using the caliper slide, measure the depth from the top of the piston to the top of the piston pin. This length shall measure 20.5mm +/- 0.05mm.

Remove the Piston Ring from the piston and using calipers, measure the thickness of the piston ring. This thickness shall measure a min of 0.96 mm.

Remove the Piston Pin from the piston and using the calipers, measure the length of the piston pin. This length shall not measure less than 46.5mm long. The diameter of the piston pin shall also be of 15mm design.

1.2 Cylinder Base Gasket(S):

Remove the cylinder base gasket/s. The engine must have the minimum requirement of 1x OEM 1999 CR125 base gasket identified as being yellow in colour on one side, tan in colour on the other. This base gasket is of 0.5mm thick in design when measured with the caliper. Any additional base gaskets included to the OEM base gasket described is allowed.

1.3 Crankcases and Crankshaft Assembly Inspection:

Rotate the crankshaft towards TDC. The connecting rod must be of uniform gold/brown colour with no polishing evident and display a cast marking of "KZ4A".

The ignition side of the crank wheel must be stamped with a "G", evident when the crank wheel is close to TDC. Inspect the crankcase transfer area for modifications with respect to the specified regulations.

1.4 Carburettor:

Inspect carburettor for any modifications. Control measurement as outlined in these regulations.

1.5 Carburettor Boot and Reed Block:

Inspect carburettor boot for any modifications. It must have KZ4M cast externally on the black rubber boot.

Inspect reed block for any modifications. The body will be of gold/yellow colour with no grinding evident. The pedal windows must have a black rubber coating without any evidence of grinding. OEM reed stops must be fitted.

1.6 Exhaust Pipe Chamber / Muffler:

The exhaust pipe is stamped on its rear cone from the inside with "RLV R4H". The pipe must not show any signs of modification from its unique manufactured formation. The muffler fitted must comply with the specified regulations.

1.7 Ignition:

Inspect the CDI, Ignition Coil, Generator and Flywheel for any visual modifications and ensure they conform to their respective regulations.

The SKUSA timing plate is machined with identification on its body and is anodised in blue. Using the official supplied SKUSA plate; a direct comparison can identify any modifications, specifically to the adjusting slot or mounting holes.



1.8 Gear Ratio:

With engine drive sprocket removed, install the degree wheel to the drive shaft of the engine.

Select gear and rotate the crankshaft to take up the load within the gearbox.

Once established and the degree wheel is set, the degree wheel shall rotate the following angles for each gear indicated below after exactly three revolutions of the crankshaft. If measurement fails within the tolerance, retry above procedure and/or ensure correct gear is referred to.

First Gear	145 degs	+/- 1 deg
Second Gear	184 degs	+/- 1 deg
Third Gear	225 degs	+/- 1 deg
Fourth Gear	266 degs	+/- 1 deg
Fifth Gear	303 degs	+/- 1 deg
Sixth Gear	343 degs	+/- 1 deg

1.9 Weight:

The minimum combined kart/Driver weight for Superkart events shall be as follows:

Class		kg
125cc	Non Gearbox – Light	165
	- Heavy *	185
125cc	Non-Gearbox Junior	140
125cc	Stock Honda Gearbox	180
125cc	Gearbox	190
250cc/ 450cc	Gearbox National	208
250cc	Gearbox International	218

* Maximum kart-only weight of 100kg (125 NGB class only)

- (a) All ballast must be securely fastened to the chassis or seat. The wearing of weight belts by the Driver is forbidden.

- (b) Any kart/Driver combination found to not meet the minimum weight shall be excluded from that part of the event in which the irregularity was detected. The owner and Driver shall be reported to the Stewards for further penalty.

1.10 General:

The construction of the kart shall be such as to satisfy the scrutineers as to its soundness and safety.

Timing transmitters when fitted shall be located with the whole of the unit and mounting behind the front axle centre line straight ahead position.

1.11 Championships:

For State and National Championships, only two engines per Driver may be accepted at scrutineering for use during such championship events.

At every State and National Championship circuit race event, all gearbox classes shall be limited to the use of eight tyres save for 250cc Gearbox International Class for which the number of tyres is not restricted. Except for:

- (a) treaded tyres used on a damp or wet track, up to eight dry weather (slick) tyres (four front and four rear) may be used for all races at each event.
- (b) These tyres shall be coded and marked by scrutineers prior to the first qualifying session. Included on the marking on the dry weather (slick) tyres shall be the competition number of the relevant kart, the circuit, and/or any other marks deemed necessary by the Chief Scrutineer.
- (c) The use of unmarked, incorrectly marked dry weather (slick) tyres during any race is prohibited.
- (d) No tyre marked for the use by one kart may be used on another kart during that circuit race event.
- (e) The onus and responsibility lies with the Competitor to ensure that scrutineers mark their tyres in accordance with these regulations.
- (f) In the event of wet or damp conditions at the start or during any heat or race it is permitted to use unmarked wet weather tyres.
- (g) The Chief Scrutineer shall be the sole Judge of Fact in respect of decisions on tyres. Any contravention of this article may result in the Competitor and/or Driver being referred to the Stewards for disciplinary action.

At every State and National Championship circuit race event, 125cc Non-Gearbox Class shall be limited to four tyres (two front and two rear).

In the event of a declaration by officials of “Wet Track” Competitors must use wet weather tyres, until such time as the event may be declared “Dry Track”. Non-Gearbox Classes are restricted to one set of four marked wet weather tyres (two front and two rear) for the duration of the event.

The markings and procedures shall be as per the above for gearbox classes, save that one front tyre and one rear tyre may be replaced, if a marked tyre has been damaged, at the sole discretion of the Scrutineer. No tyre replaced under this provision shall be used again at this circuit race event.

Note: Where conflict between Article 12 of these regulations and the Australian Superkart Championship Sporting Regulations exists, the Sporting Regulations shall take precedence.