

# Safety Cage Registration

## Type 3 - Full Cage

Please submit this application and log book (is applicable) to: **logbooks@motorsport.org.au**  
or **Motorsport Australia, PO Box 172 Canterbury LPO, VIC 3126**

**Original registration document shall remain with the vehicle's Log Book.**

### Vehicle and Customer Details

The structure outlined below is manufactured for the following vehicle:

<b>MAKE</b>	<b>MODEL</b>
<b>CHASSIS NO.</b>	<b>ESTIMATED VEHICLE WEIGHT</b>
<b>CUSTOMER NAME</b>	<b>LICENCE NO.</b> <i>(if applicable)</i>

### Manufacturer's Details and Declaration

I declare the Safety Cage Structure described on this form was manufactured by me or under my supervision to comply with the material, configuration and mounting requirements of Motorsport Australia in force at the time of registration.

**NAME OF MANUFACTURER**

**ADDRESS**

**SUBURB**

**STATE**

**POSTCODE**

**PHONE**

**EMAIL**

**NAME**

**SIGNATURE**

**COMPLETION DATE OF SAFETY CAGE STRUCTURE**      -      -

**Attention:** The issue of this document does not signify that the structure has been accepted by Motorsport Australia as being in compliance with the requirements for Safety Cages as specified in Schedule J of the Motorsport Australia Manual.

### Structure Details

Component	Main Hoop	Backstays	Diagonals	Front Leg
<b>Steel Type</b>				
<b>Outside Diameter</b>	mm	mm	mm	mm
<b>Wall Thickness</b>	mm	mm	mm	mm

**METHOD OF ATTACHMENT TO VEHICLE**      FULLY WELDED      BOLTED TO WELDED REINFORCEMENTS      BOLTED ONLY

#### DETAILS OF STRUCTURE

Draw the additional members using a ruler within the basic structure below. For clarity; it is only necessary to show side intrusion bars and braces fitted to one side of the cage unless the other side is different. The type of dismantable joints used must be listed on the drawing and then identified at each location (eg. J-51 = O, a circle "O" is then placed on the drawing at the joint location.)

#### TYPE OF COMPETITION

SPEED	DRIFTING
AUTO TEST	OFF ROAD
RALLY	RACE

#### HIGHEST LEVEL OF COMPETITION

CLUB

STATE CHAMPIONSHIP

NATIONAL SERIES OR CHAMPIONSHIP

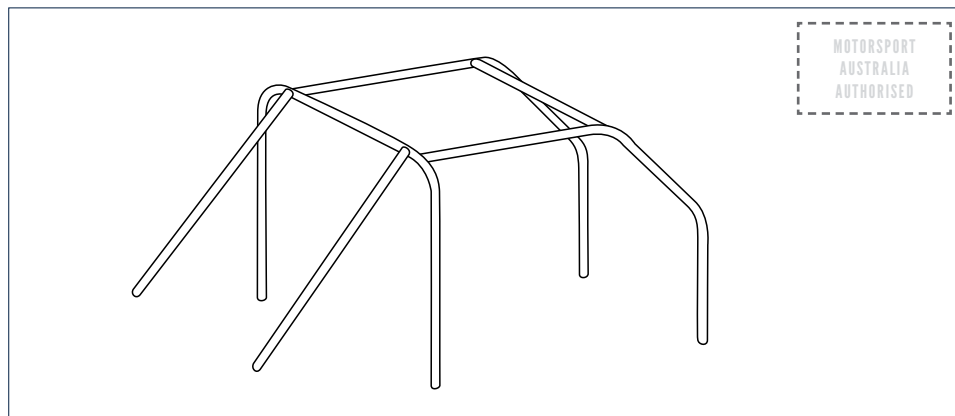

Note: Write the letters NF where members are not fitted as part of the Safety Cage Structure

### MOTORSPORT AUSTRALIA USE ONLY

SAFETY CAGE STRUCTURE SERIAL NO.

REGISTRATION ISSUE DATE

REMARKS OR RESTRICTIONS

LOG BOOK NO.

AUTHORISING OFFICER

VEHICLE ID NO.

SIGNATURE

### Instructions to Safety Cage Manufacturers and Vehicle Owners

#### SAFETY CAGE STRUCTURE PICTURES MUST BE SUPPLIED WITH APPLICATION

**Safety Cage Registration can be completed once the Safety Cage is installed and prior to a Log Book application.**

**Note 1:** It is the responsibility of the Manufacturer to:

- Read and understand Schedule J of the Motorsport Australia Manual prior to the fabrication of a Safety Cage Structure
- Ensure the accuracy of the information supplied to Motorsport Australia

**Note 2:** This form is to be used only where the safety cage is added to a conventional car body, and is not part of a space frame or tub style chassis.

**Note 3:** Do not use this form with Certified or Homologated Safety Cage Structures.

**Note 4:** The issue of this document does not signify that the structure has been accepted by Motorsport Australia as being in compliance with the requirements for safety cages as specified in Schedule J of the Motorsport Australia Manual, or the relevant Group Technical Regulations.

**Note 5:** The use of ERW pipe (to AS 1163), which is not drawn to size by a Cold Finishing Process, is not permitted unless the Safety Cage is Certified by Motorsport Australia with an Engineers certification.

External dimensions of 42.4mm or 48.3mm normally indicate that the tube is ERW, a Cold Formed, not a Cold Drawn or Finished tube.

**Note 6:** Chrome Moly is not permitted unless the Safety Cage Structure is Certified by Motorsport Australia.

**Note 7:** If this document is submitted to Motorsport Australia without a log book application a postal address must be provided in order for Motorsport Australia to return the original document and safety cage structure sticker to the customer/manufacturer.

**Note 8:** If this safety cage structure is installed in a vehicle which has been log booked by Motorsport Australia, the log book is required to be sent to Motorsport Australia along with this document for the appropriate amendments to be filled in by a Motorsport Australia Officer.

**Tube Type:** The tubing type is to be shown as one of the following:  
CDS - Cold Drawn Seamless

CDW - Cold Drawn Welded  
CEW - Cold Drawn Electric Resistance welded.

These descriptions are shown on the Product Sheet which should be obtained from your steel supplier with each batch of tubing you purchase.

**Dimensions:** These sizes refer to the external diameter of the tube and the wall thickness. They will normally be 44.45mm OD for the main hoop and 38mm OD for all other braces, with wall thickness of 2.5mm or greater. This detail is also shown on the Product Sheet for the tubing.

**Photos:** Your email app needs to send them in medium to large size.

Please supply:

- A photo of the driver's door opening
- Step up to the driver's door and take photos of the passenger side attachment points of the front hoop to the floor, main hoop to the floor, and backstay to the body.
- If any members are fitted in the roof, take a photo from the driver's seat upwards to show them.
- General photos only, no close ups as we will zoom and crop the photos where needed.

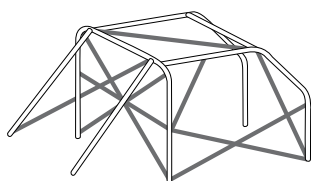

### Customer Details

NAME		MOTORSPORT AUSTRALIA LICENCE NO.	
POSTAL ADDRESS			
SUBURB		STATE	POSTCODE
DATE OF BIRTH	/ /	PHONE/MOBILE	
EMAIL			

### Payment

**Pre-Log Book Safety Cage Registration: \$32.00 (inc. gst)**

(If submitted with a Log Book Application the price for Safety Cage Registration will be \$32.00 and included in the fee for the Log Book)

**PAYING BY**  
(please tick appropriate box)

CASH  
(ONLY if paying in person at a Motorsport Australia Office)

CHEQUE/MONEY ORDER  
(made payable to "Motorsport Australia")

CREDIT CARD  
(please complete details)

**CARD NUMBER**

**EXPIRY** /

**CVV**

**CARD TYPE** VISA

MASTERCARD

**NAME ON CARD**

**SIGNED**