

CIRCUIT RACE APPENDIX

1st Category – Racing Cars

Formula Ford – Technical Regulations

Modified Article	Date of Application	Date of Publication
3.10(a)	01/01/2024	01/01/2024
4.9 (d), (e), (f) and (g)	01/01/2024	01/01/2024
14.1	01/01/2024	01/01/2024
App. B Drawing 4: Clutch and Flywheel Ass.	01/01/2024	01/01/2024

PREAMBLE

The Formula Ford Association Inc. (FFA) is recognised by *Motorsport Australia* as the sole entity representing competitors in Formula Ford Competition. The FFA shall be responsible for the consultation processes within its membership and with other interested parties as may be appropriate from time to time. *Motorsport Australia* is ultimately responsible for the approval of the regulations and changes thereto, and responsible for publishing the regulations and associated bulletins as necessary.

The Formula Ford Association Incorporated (FFA)

(ABN: 42 015 166 048)

Administrator: Phil Marrinon

C/- 13 Aintree Avenue

Mulgrave Vic 3170

Mob: (0422) 840 300

Email: admin@formulaford.org.au

For Formula Ford using the original 'Kent' engine, please refer to the Formula Ford 1600 regulations approved by *Motorsport Australia*.

1. GENERAL

Each automobile must:

Conform with the Technical Appendix in the *Motorsport Australia Manual* and these regulations. Each *Automobile* must also be the subject of a current Certificate of Origin, issued by FFA.

2. ELIGIBILITY

2.1 General:

Formula Ford is open to single-seater cars with open coachwork as defined by *Motorsport Australia*, using a standard 1600cc Duratec engine described in Article 4 below and complying with Schedules A, B and C (refer to Technical Appendix) and the specifications for 1st Category – Racing Cars, as published in the *Motorsport Australia Manual*.

2.2 Racing Weight:

The minimum racing weight at any time, including the driver with helmet and wearing all apparel (e.g., as at the end of a race or practice) shall be 510kg as recorded on the scales at the circuit on the day of the event.

Any ballast which is carried must be securely fixed (i.e. welded, riveted or bolted) and located in a position able to be readily checked.

2.3 Year of Manufacturer:

Only chassis manufactured after 1 January 2001 (identified with a manufacturer's chassis plate confirming the date of construction) and complying with Schedule J – Safety Cage Structures (Technical Appendix), are eligible to be fitted with the Duratec engine.

2.4 Standard Components:

All standard components and settings must remain as supplied by Ford Motor Co. unless these regulations state otherwise.

3. CHASSIS

3.1 Composite Materials:

The use of stabilised/composite materials incorporating carbon and/or Kevlar® reinforcement is prohibited SAVE where specifically authorised.

3.2 Chassis Construction:

- (a) The chassis must be of tubular steel construction with no stress-bearing panels except bulkheads and undertray. The curvature of the undertray must not exceed 25mm.
- (b) Monocoque chassis construction is prohibited. Stress-bearing panels are defined as sheet metal affixed to the frame by welding, bonding or rivets or bolts or screws which have centres closer than 150mm.
- (c) Bodywork must not be used as stress-bearing panels.

3.3 Lateral Protection Structures:

- (a) Each Formula Ford chassis is required to be constructed to incorporate a lateral protection structure on each side of the car as follows (refer also to Appendix A):
- (b) A lateral protection structure is defined as a continuous panel whose projection on a vertical plane parallel to the longitudinal axis of the car shall be at least 150mm high, to a minimum distance of 550mm from the car's longitudinal centre line between at least the transverse planes passing through the fuel tank rear face and the frontal extremity of the minimum cockpit overall opening length, and at a minimum distance of 350mm from the car's longitudinal centre line between at least the transversal planes passing through the above extremity and the front rollover bar hoop.
- (c) The lateral protection structures shall be made from a composite material of 3000mm² minimum cross section with a honeycomb core in metal or Nomex® giving adequate resistance to compression.
- (d) The external skins shall be of aluminium alloy or plastic of a minimum thickness of 0.5mm or made up of another assembly of materials of equivalent efficiency.
- (e) The panels must be securely attached to the bottom and at the upper extremity to the main structure of the car in such a manner as to ensure absorption of a lateral impact.
- (f) The radiators may play the role of protective panels or of transversal struts.
- (g) The periphery of the bodywork covering the lateral protection structure, when viewed from below, must be curved upwards with a minimum radius of 50mm, and a maximum radius of 70mm with the exception of air entry and exit openings into the lateral protection structure. The floor of the side pod must reflect the plan of the upper surface.
- (h) The floor is to be in the same plane as the undertray in both directions, i.e. transverse and longitudinal, subject to all points being within 25mm of any flat plane situated under the car (see 3.2).

3.4 Cockpit Specifications:

- (a) Each car must comply with the following:
 - (i) the internal cross-sectional area of the cockpit from the soles of the driver's feet to behind the seat shall nowhere be less than 0.07m². The minimum width must be 250mm over the whole length of the cockpit.
 - (ii) The only intrusion permitted into the cross-sectional area is the steering column; the driver's feet (in normal position, pedals not depressed), must be located behind a transverse vertical plane drawn through the front wheel axes.

3.5 Tubes within the Cockpit:

No engine oil or water tubes are permitted within the cockpit.

3.6 Impact Absorbing Structure:

- (a) Each chassis subject of a log book first issued after 1 January 2008 must include an impact-absorbing structure fitted ahead of the front bulkhead of the tubular steel frame. This structure must be independent of the main bodywork and must be solidly fixed to the extremities of the bulkhead (i.e., with bolts requiring tools for removal).
- (b) It must constitute a box of 300mm minimum length, 150mm minimum height in any vertical section and 40,000mm² minimum total cross section. It must be metallic using honeycomb sandwich construction with a minimum panel thickness of 13.9mm. The main bodywork is defined as the external covering of the chassis frame from the foremost steel bulkhead to the centreline of the rear wheels.
- (c) The impact-absorbing structure shall be fixed to the chassis with a minimum of four fasteners, in high quality steel using a core diameter of 6mm minimum. Irrespective of the size of the impact absorbing structure (safety foot box), the maximum total area of access holes allowed in the walls of this structure shall be 15,000mm².
- (d) The basic structure is defined as a unit with five closed sides and one open side. The access hole dimensions quoted apply to any modification to the five closed sides. (Minimum clearance holes for the passage of steering rack/rods are not included in the calculation of this area.)

3.7 Nose Boxes:

Nose boxes/cones manufactured in ferrous materials (e.g., steel) are prohibited.

3.8 Cockpit Protection:

- (a) Each chassis subject of a log book first issued after 1 January 2007 shall comply with the following:
 - (i) Above the level of the Lateral Protection Structure, and up to the level of the upper chassis tube, stretching from the rear roll hoop to the front roll hoop, there must be an anti-intrusion panel.
 - (ii) This anti-intrusion shall be either built into the removable bodywork or keyed into the main chassis but cannot be rigidly attached to the chassis. It can be made from glass reinforced plastic, Kevlar® or aluminium skin added to the inner face of the removable body panel.
 - (iii) Any material added must considerably improve the anti-penetration capability of the structure in the area of the driver.
- (b) If the side protection is built into the bodywork alongside the driver the minimum requirement is a double layer, 141.75g/m² (5oz), bi-directional, laminated Kevlar® (Aramid) material.

3.9 Cockpit Opening:

- (a) Each chassis subject of a log book first issued after 1 January 2007 shall comply with the following:
 - (i) The opening giving access to the cockpit must allow a designated horizontal template to be inserted vertically into the cockpit (not considering the steering wheel, the removable seat or any side head support) down to 250mm lower than the lowest point of the cockpit opening.
 - (ii) This template is defined by dimensions J, K and L in the Table of Dimensions in Appendix A.

3.10 Roll Over Protection:

- (a) A roll bar is required to be fitted behind the driver's head [complying with Motorsport Australia Manual – Technical Appendix, Schedule J](#). ~~It must be configured so that the top of the driver's helmet is 50mm vertically below the top of the roll bar, and at least below a line drawn from the top of the roll hoop to the top of the front bulkhead (see points 1 and 2 on the diagram accompanying the Table of Dimensions in Appendix A).~~
- (b) The roll bar must be either:
 - (i) made from 38mm x 2.5mm cold drawn seamless tubing and comply with the configuration shown as Type 1; or
 - (ii) an alternative design capable of withstanding a vertical load of 36.4 kN and a load of 26.7 kN applied at the top of the roll bar and directed horizontally to the rear. Such a design must be certified by Motorsport Australia or another ASN.

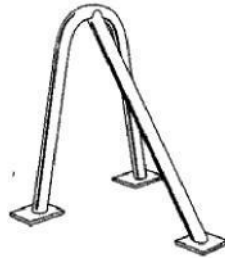

Type 1: Solo Roll Bar

3.11 Safety Harness:

Each car shall be fitted with a Type A safety harness in accordance with the requirements of Schedule I (Technical Appendix).

3.12 Ride Height:

No part of the car, except for tyres, may be closer to the ground than 40mm. This measurement will be taken with the driver seated at the steering wheel, the car in race trim and with the wheels pointed straight ahead.

4. ENGINE

4.1 Permitted Engine:

- (a) Only the Ford 1600cc Duratec unit fitted to the WB Fiesta is permissible.
- (b) Engines are to be purchased through FFA. Each engine will be supplied with a total of eight seals, one on each of the following components:
 - (i) Front seal housing bolt,
 - (ii) rear seal housing bolt,
 - (iii) crankshaft pulley bolt,
 - (iv) cylinder head to cylinder block,
 - (v) inlet and exhaust camshaft bearing cap bolts and inlet and exhaust camshaft front pulley bolts.
- (c) Additional seals may be fitted at the sole discretion of FFA.
- (d) Once the engine has been sealed by FFA or the nominated engine repairer, the seals must remain intact and legible at all times. Seals can only be removed by FFA, the nominated repairer or with the express prior approval of, and subject to, the conditions of FFA.
- (e) Should an event official or the nominated repairer identify evidence of possible tampering or removal of seals, without evidence of prior approval, the owner of the engine will be required to return the engine to the nominated repairer for a complete rebuild and re-seal, including a dyno check, at the owner's cost, BEFORE the engine is permitted to be used again in competition.
- (f) Each engine will be individually identified with a unique serial number.

4.2 Engine Mounting:

The engine shall be mounted upright, aligned fore and aft in the chassis and additionally the crankshaft centre line must be on the longitudinal centre line of the vehicle.

4.3 Addition of Materials:

The addition of any material, be it metal, plastic or composite etc, by any means be it welding, bonding, encapsulation or encasement to any component is prohibited. Specific repair of castings may be allowed with written approval of FFA.

4.4 Balancing:

Balancing of the flywheel and clutch is permitted, provided only minimal localised weight is removed and the minimum weights detailed in Article 4.9 (g) and (h) are respected.

4.5 Exhaust System:

- (a) The exhaust manifold must use the standard gasket and the specified mounting flange at the cylinder head face.
- (b) The primary pipes must be 38mm (1 1/2") OD, 800mm long and 1.6mm wall thickness. The secondary pipe must be 50mm (2") OD and 1.6mm wall thickness.
- (c) The Specified collector, available through FFA, must be fitted. The external surface of the collector may be modified to fit locating clips and by painting. No other modifications are permitted.
- (d) The internal surface of the collector must remain as supplied.
- (e) The primary pipes will be measured by volume, and the average volume of each pipe including the mounting flange shall be 760cc ± 2%. To allow for individual primary pipes it is permitted to section the mounting flange.
- (f) A muffler providing noise abatement complying with the requirements of *Motorsport Australia* must be fitted at all times during practice and racing.

4.6 Lubrication System:

The Specified sump must be used. External to the engine, the only scavenge pump allowed is the Specified component. The remainder of the lubrication system, including oil coolers, is free.

4.7 Cooling System:

- (a) A water based cooling system is mandatory.
- (b) The drive from the crankshaft to the water pump is free, and consequently the rotational speed of the water pump may be changed. The pulleys, belts and retention bolts driving the water pump are free.
- (c) The thermostat housing and water outlet housings are free. The thermostat may be removed. The original engine water circulation concept and the standard water pump must be retained.
- (d) No other pump or motor may be used to circulate or assist circulation of the coolant liquid.

4.8 Crankshaft Pulley:

The crankshaft pulley is free as are the drive belts and pulleys for the alternator and scavenge pump.

4.9 Flywheel and Clutch:

- (a) The flywheel must be the specified component. No other machining is allowed. For rectification the clutch mating face may be resurfaced, providing the minimum weight is respected.
- (b) The position of the ignition mark on the flywheel relative to the crankshaft must remain within **Ford** design limits at all times.
- (c) The clutch plate must be the specified component.
- (d) The clutch cover must ~~remain standard~~ be the specified component.
- ~~(e) Flywheel bolts must remain standard.~~
- ~~(f) It is permitted to secure the ring gear to the flywheel.~~
- (g) For **Current Clutch and Flywheel**, ~~eligible from Jan 1 2018~~ Refer Appendix 4, Drawing 4: Clutch and Flywheel Assembly:
 - (i) Flywheel minimum weight shall be ~~6.3kg (excluding all bolts)~~ **4.45kg 4.35kg** (excluding all bolts).

Flywheel and clutch cover minimum weight shall be ~~9.6kg 6.9kg~~ **6.8kg** (excluding all bolts). Localised machining of the cylinder block is permitted only to allow fitting into the chassis. It is prohibited to remove any identification markings.

4.10 Induction System:

- (a) The induction system shall remain in conformance with the relevant diagrams in Appendix B, specifically:
- (b) Inlet manifold - the inlet manifold must be the Specified component.
- (c) Throttle body - the throttle body must be the Specified component.
- (d) Air filter - the air filter must be the Specified component.

4.11 Non-Standard Fasteners:

The use of non-standard replacement fasteners, nuts, bolts, screws, studs and washers which are not connected with or which do not support any moving parts of the engine or its compulsorily retained accessories is permitted. All engine gaskets must be standard. The use of thread locking compounds is permitted.

5. TRANSMISSION

5.1 Gearbox:

The gearbox must contain not more than four forward gears and shall include an operable reverse gear, capable of being engaged by the driver whilst normally seated. The main cluster must be wholly behind the rear axle output shaft centre line, and be parallel with the crankshaft centre line.

5.2 Gear Selection:

Gear selection must be via a direct mechanical connection to an "H-Pattern" gear shift lever operated by the driver. Electronic, hydraulic or pneumatic assisted systems are prohibited.

5.3 Ratios:

A control first gear is mandated according to diff ratio. Diff ratio 10/31 and First gear ratio 15/36 or Diff ratio 13/36 and First gear ratio 14/36. All other ratios are free.

5.4 Drive Wheels:

Only rear-wheel drive is permitted.

5.5 Final Drive:

(a) The final drive ratio is free.

(b) Torque biasing, limited slip and locked differentials are prohibited. The use of non-ferrous material in differential components is prohibited, save that the thrust washer, Hewland Part No. HC8-214-5R, manufactured from plastic, is permitted in Hewland gearboxes.

6. SUSPENSION AND STEERING

6.1 Composition:

All parts of the suspension system must be of steel or ferrous material, with the exception of bellcranks, tracking or alignment arms, hubs, hub adaptors, hub carriers, bearings and bushes, spring caps, abutment nuts and anti-roll bar links.

6.2 Active Suspension:

Active suspensions are prohibited, as is any system which allows control of the flexibility of the suspension springs, shock absorption and trim height whilst the car is moving.

6.3 Shock Absorbers:

Shock absorbers are free, save that vehicles cannot be fitted with more than four; i.e. no more than two at the front and two at the rear. Interconnection of fluid between units and mechanical interconnection between front and rear units is not permitted.

6.4 Steering:

The complete steering system is free.

7. WHEELS AND TYRES

7.1 Wheels:

(a) Each car must be fitted only with the Specified Performance or VTO alloy wheels, as detailed below:

Front	13" x 6"	Part no. 100FF	100mm PCD
	or	Part no. 095FF	95mm PCD
Rear	13" x 7"	Part no. 100FF	100mm PCD
	or	Part no. 095FF	95mm PCD
Front	13" x 6"	Part no. JF514	100mm PCD

	or	Part no. JF514	95mm PCD
Rear	13" x 7"	Part no. JF514-1370	100mm PCD
	or	Part no. JF514-1370	95mm PCD

- (b) Wheel colours - Re-painting of wheels is permitted.
- (c) Minimum weight – Front wheels 4.7 kg Rear wheels 5.05 kg
- (d) Safety checks - for safety reasons, it is strongly recommended that weekly checks are carried out and that wheels are renewed at least once every year.
- (e) Wheel bearings - only wheel bearings manufactured from ferrous materials are permitted.

7.2 Tyres:

- (a) The make, type, specification and dimensions of the tyres permissible for use in Formula Ford competition racing shall be advised from time to time.
- (b) The permissible tyres are:
 - (i) **YOKOHAMA: A048 soft compound**
 - (A) **FRONT** - 185/60HR13 A048S article # K9729
 - (B) **REAR** - 205/60HR13 A048S article # K9730
- (c) Tread Depth: At the commencement of any official timed practice, qualifying session or race, the depth of the tyre tread, measured alongside the tread wear indicator, must be at least a minimum of 1.5mm. Isolated flat spots may not render a tyre ineligible unless deemed unsafe for competition. The original tread pattern must always remain visible on any tyre that is fitted to any automobile.
- (d) The use of any device to artificially heat the tyres is prohibited.
- (e) Protective tyre covers may be used in the paddock area. Their use is prohibited in the assembly, impound and scrutiny areas and they must not be re-fitted until after all post-session checks are completed.
- (f) Tyres must only be inflated with air.
- (g) With the exception of wear resulting from friction with the track surface, all tyres must remain unmodified.

8. BRAKES

8.1 The following applies to brakes:

- (a) The vehicle must be fitted with brakes that are operative and capable of stopping the vehicle as required.
- (b) Only brake discs made predominantly from ferrous material are permitted.
- (c) Calipers may be ferrous or aluminium alloy castings with a maximum of two working cylinders per caliper.
- (d) The vehicle shall be equipped with two independent brake circuits, so that, in event of failure of one system, braking is maintained on at least two wheels.
- (e) The vehicle must have brakes on all wheels.
- (f) The vehicle must not be fitted with an anti-lock braking system.
- (g) Brake cooling ducts are not permitted.
- (h) Cross-drilling of brake discs is prohibited.
- (i) Competitors are required to use Ferodo brake pads, compound numbers DS2500, DS3000 or DS4300.

9. FUEL SYSTEM

9.1 Fuel Tank:

- (a) Only an FT3 or superior FIA specification tank is permitted.

(b) Maximum capacity of fuel tank: 41 litres.

9.2 Fuel Pump:

The fuel pump is free.

9.3 Fuel Pipes:

Fuel pipes are free.

9.4 Cooling Radiators:

Fuel cooling radiators are not permitted.

9.5 Fuel Pressure:

With the engine at operating temperature, and the engine idling, the pressure at the fuel rail shall be 370KPA \pm 10KPA with the manifold vacuum disconnected from the pressure regulator.

9.6 Fuel Sampling:

A dry break fuel sampling coupling at the fuel rail is mandatory.

9.7 Fuel Temperature Changes:

Any device or substance, which changes the temperature of the fuel from the ambient air temperature, is prohibited.

9.8 Fuel:

(a) Only pump fuel complying with Schedule G (Technical Appendix) may be used except that fuel containing more than 2% ethanol is not permitted

(b) All fuel must be used without any additives.

10. ELECTRICAL EQUIPMENT

10.1 Alternator:

The standard alternator must be operational at all times during competition. Location is free.

10.2 Spark plugs:

Spark plugs are free, provided they are a standard replacement for the engine.

10.3 Starter motor:

It is permitted to replace the nose housing of the standard starter motor.

10.4 Ignition coil:

The Specified ignition coil must be used and may not be re-positioned.

10.5 Wiring loom:

The Specified engine wiring loom must be used.

10.6 Specified sensors:

The Specified water temperature and oil pressure sensors must be used.

10.7 ECU:

(a) The Specified ECU must be used. Firmware, software and settings (e.g. maps) shall be regarded as part of the ECU.

(b) The ECU diagnostic connector must be positioned in an accessible position allowing a scrutineer free access to it at all times, including if the driver is seated in the car and fully prepared to take part in the competition.

10.8 Rain light:

(a) The centre of the light must be placed not less than 300mm from the ground, and less than 300mm from the rearmost part of the car.

10.9 Data recording:

(a) each car may only be fitted with one data recording unit and unless otherwise specified, one of each of the following sensors:

- (i) **General Sensors:**
 - (A) front wheel speed (x 2);
 - (B) steering angle;
 - (C) G-force longitudinal;
 - (D) G-force lateral;
 - (E) Gforce vertical;
 - (F) suspension position (x 4);
 - (G) brake line pressure front;
 - (H) brake line pressure rear;
 - (I) battery voltage;
 - (J) oil temperature;
 - (K) cockpit temperature;
 - (L) beacon input;
 - (M) lambda;
 - (N) water pressure sensor; and
 - (O) global positioning sensor (GPS).
- (b) Random data sampling may be undertaken by the Scrutineers or Technical Delegate. Telemetry devices are prohibited.
- (c) The fitment of an electronic timing device as required by the circuit timing systems is permitted. Timing transmitters must be fitted, in accordance with the manufacturer's instructions, with the leading edge at a position no less than 1.6m behind the point of the nose of the car, unless otherwise directed by event officials.
- (d) Fitment of video recording devices may be fitted subject to approval by the scrutineers.

11. BODYWORK

11.1 Bodywork:

- (a) Any device designed to aerodynamically augment the downforce on the vehicle is prohibited. These devices specifically include aerofoils, venturi tunnels, skirts, nose fins and spoilers of any kind.
- (b) Integration of aerofoils and spoilers by design or the mismatching of bodywork and/or chassis panels and members is also prohibited.
- (c) The bodywork must totally enclose the engine inlet manifold and filter with an opening for the passage of air.
- (d) The uppermost surface of the bodywork must not extend more than 25mm above the top surface of the rollover hoop. See additional note in Table of Dimensions, Appendix A.
- (e) The upper rear bodywork (located above the wheel centerline) is permitted to extend rearwards for a maximum of 375mm from a line drawn through the rear wheel axis. The maximum height at any part wider than 1100mm ahead of the front wheels is not to exceed the front wheel rim height.
- (f) The shape of the bodywork behind a vertical line drawn from the highest point of the roll-over bar must not include any reflex curves or flat surfaces which are capable of augmenting downforce.
- (g) The lower rear bodywork (located below the wheel centreline) is only permitted alongside and beneath the engine and may only extend from behind the cockpit to a line drawn through the rear wheel axis.
- (h) The incorporation of suspension or other fairings in this bodywork is prohibited.
- (i) It is not permitted to construct any suspension member in the form of an aerofoil or to incorporate a spoiler in the construction of any suspension member. The use of suspension fairings separate from this bodywork is prohibited.
- (j) The use of composite materials using carbon fibre reinforcement is prohibited.

12. ENGINE SEALING

12.1 Bell Housing to Engine:

At least two of the bolts fastening the housing to the engine must be cross-drilled to provide sealing of the clutch/flywheel assembly; alternatively competitors may provide for sealing of the clutch and flywheel by cross-drilling at least two of the clutch cover retaining bolts.

13. MISCELLANEOUS

13.1 Engine components:

Engine components not covered by these Regulations must remain standard and unmodified. The requirement for the use of standard parts is deemed to mean the part, as defined by the part number, prescribed by the Ford Motor Co. spare parts listing for the appropriate engine. Unless otherwise specified herein, all parts shall be "standard" parts and further, unless specifically authorised they shall not be altered in any way; and they shall be assembled and fitted in the manner intended by the Ford Motor Co.

13.2 Materials:

The use of titanium, high strength composites (e.g. carbon or Kevlar) and similar material is prohibited, save where specifically authorised in these Regulations.

13.3 Communication systems:

Communication systems, designed to provide audible communication only between the driver and pit during competition, are permitted. The communication system shall not be utilised for any other purpose.

13.4 Competition Numbers and Backgrounds:

- (a) All competitors shall use competition numbers and backgrounds of common design and size.
- (b) The backgrounds shall be white, rectangular and defined by a 3mm black border.
- (c) The background including border shall measure 190mm x 230mm. The numbers shall be 165mm high, black, of the typestyle known as **ZURICH BOLD**:

1 2 3 4 5 6 7 8 9 0

- (d) Each car must display its competition number in three locations: on the nose of the car, in a location visible to a person standing directly in front of the car at a distance of at least 10m; and one on each side of the car at a position between the rear of the driver and the leading edge of the rear wheel, at a minimum height of 300mm above the bottom of the car and above any sidepods.

13.5 Markings on Automobiles:

- (a) To differentiate the Formula Ford Category automobiles from Formula Ford 1600, the following markings are mandatory on Formula Ford Category automobiles:
 - (i) The top of the roll hoop structure shall have a prominent Day-Glo orange marking on the forward face of the structure for a minimum height of 150mm from the top of the roll hoop/bodywork.
 - (ii) ~~This marking shall extend towards the rear of the automobile for a minimum width of 50mm width or to the extent of the structure/ bodywork.~~
 - (iii) Each mirror cover shall be Dayglo orange in colour.
 - (iv) The forward facing surface of the nose, 50mm from the tip of the nose for a distance of 200mm rearwards shall carry prominent Dayglo orange marking.

14. SPECIFIED COMPONENTS

14.1 Specified Components:

Must remain as supplied, and where relevant in accordance with the diagrams in Appendix B, unless these regulations state otherwise.

Air filter	SN 2580 or AC- 4096-1	Refer Appendix B
Air temperature sensor	Bosch – Part no. 0280 130 039	

Clutch plate	SC8460-FF-18	Refer Appendix B
Clutch Plate	SC8460-FF-20 CP4429-3FM4	Refer Appendix B
Clutch Cover	CP7371-OE90-SF	
Electronic control unit (ECU)	1002 FF	
Exhaust collector	ENG0055-A	Refer Appendix B
Exhaust flange	ENG0056-A	
Flywheel	ENG0062-CA ENG000400	Refer Appendix B
Fuel pressure sensor	MLH/100PSI (Supersedes MSE/100psi)	
Fuel rail	FLS0137-A	Refer Appendix B
Fuel supply block	FLS131-A	Refer Appendix B
Fuel Injectors	98MF-BC 9F593	
Ignition coil	4M5G-120 29-ZA	
Ignition module	BIM 200	
Inlet manifold plenum	ENG0071-A2	Refer Appendix B
Inlet manifold runners	ENG0071-A1	Refer Appendix B
MAP sensor	MS-16 137 039	
Oil pressure sensor	MLH/100PSI (supersedes MSE/100psi)	
Pcv cover plate	ENG0138-A	
Scavenge pump	ZIP SE 10L	Refer Appendix B
Sump	ZIP SE 1.6	
Throttle body	ENG0063-A	Refer Appendix B
Throttle position sensor	0 261 211 003 or or Premier# FF101B	Refer Appendix B
Water temperature sensor	Bosch – Part no. 0280 130 026	
Wheels	Performance alloy wheels - Part nos. 100FF or 95FF	
Wiring loom	MSE F/FORD Rev 1	Refer Appendix B

15. FOREWARNING OF POSSIBLE FUTURE CHASSIS CHANGES

Chassis Changes:

- (a) The Ford Motor Company (UK), the Motor Sports Association United Kingdom (MSA UK) and the FIA have been working together toward a common set of safety regulations for tubular steel single-seater chassis. This process has been completed and these recommendations will be incorporated into the UK Formula Ford Regulations.
- (b) Consideration will be given to the introduction of elements of these regulations into Australian competition, as part of the ongoing process of aligning Australian regulations as closely as practical to those in other countries. All participants will be advised of the process of these changes as soon as information is available.

Appendix A – Table of Dimensions

DRAWING: SINGLE SEATER DIMENSIONS

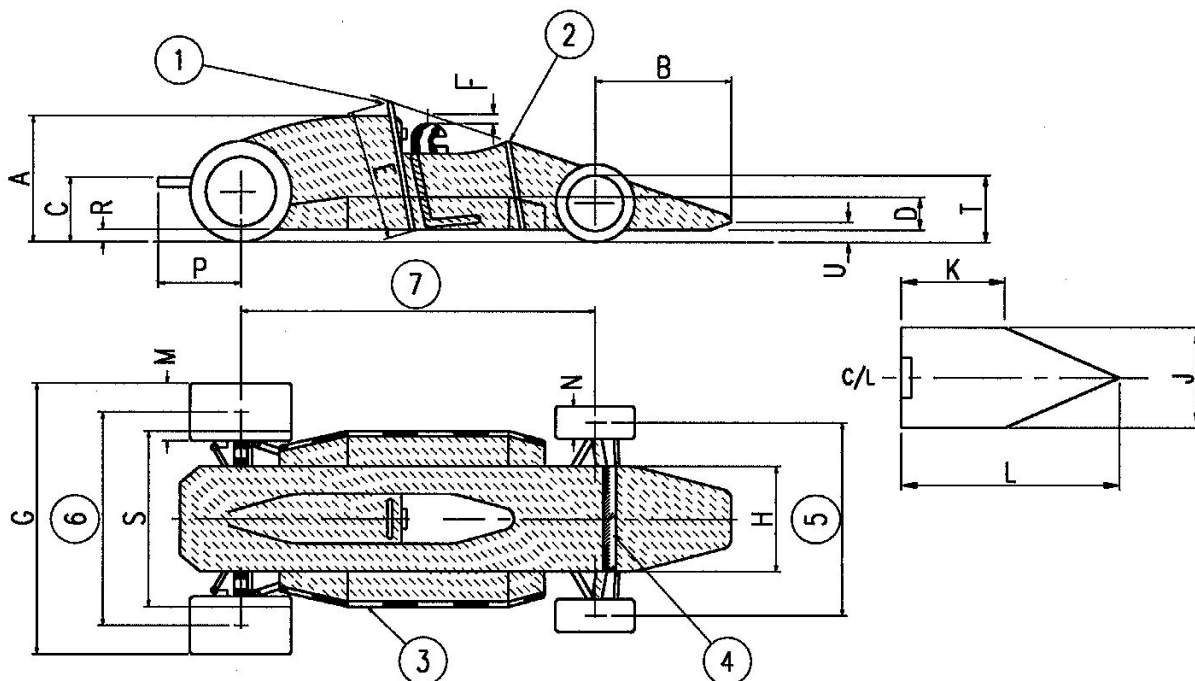

TABLE 1

Refer to drawing	
1	Type 1 Safety Cage Structure
2	Substantial Support Structure
3	Lateral Protection Structure
4	Substantial Support Structure
5	Front Track
6	Rear Track
7	Wheelbase
NOTE	Maximum height is measured with the driver aboard.
	Maximum height excludes Type 1 Safety Cage Structure on which there is no maximum height.

TABLE 2

Refer to drawing – All dimensions in mm unless specifically stated		
A	Maximum body height measured from the ground *	900
B	Maximum front overhang from front wheel axis	1000
C	Exhaust height measured from the ground	600 (max)

D	Minimum height of lateral protection structure	150
E	Minimum safety roll over bar length in line with driver's spine	920
F	Minimum allowed helmet clearance	50
G	Maximum width	1860
H	Maximum body width behind front wheels	950
J	Minimum cockpit opening	450
K	Minimum cockpit parallel opening length	300
L	Minimum cockpit overall opening length	600
M	Maximum rear wheel width	7" (inch)
N	Maximum front wheel width	6" (inch)
P	Maximum exhaust length from rear wheel axis	600
R	Minimum ground clearance	40
S	Maximum width including lateral protection structure	1300
7	Minimum wheelbase	2000
5 / 6	Minimum track	1200
	Wheel diameter	13" (inch)
NOTE	The maximum height of any part wider than 1100mm ahead of the front wheels is not to exceed the front rim height	
*	Except for within 450mm rearward of the front face of the roll bar and for a maximum of 150mm either side of the longitudinal roll bar centre line, where bodywork may be present but shall not be more than 25mm higher than the upper surface of the roll bar.	

Appendix B – Specified Component and Information Diagrams

DRAWING 1: THROTTLE BODY ASSEMBLY

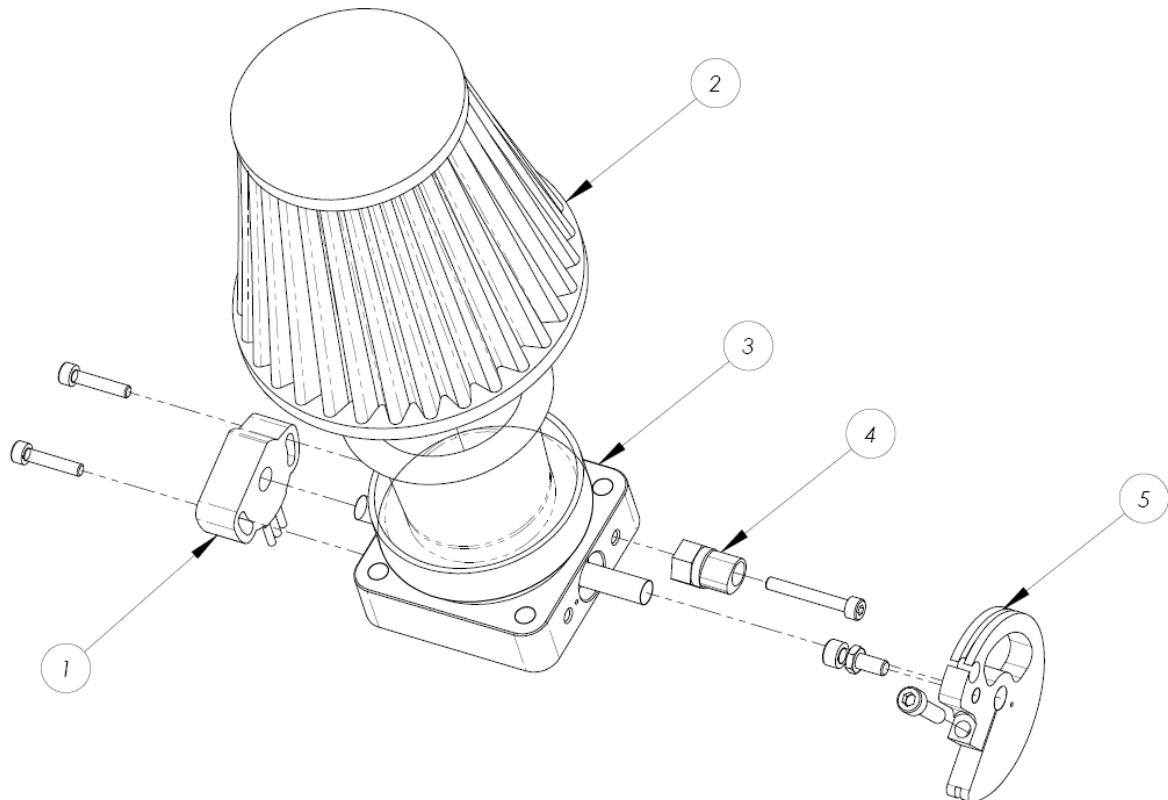

1	0 261 211 003 Bosch TPS or Premier part # FF101B
2	SN-2580 or AC-4096-1 K&N Air Filter
3	ENG0063-A Throttle Body
4	ENG0130-A Throttle Stop
5	ENG0066-A Throttle Wheel

DRAWING 2: THROTTLE WHEEL ENG0066-A

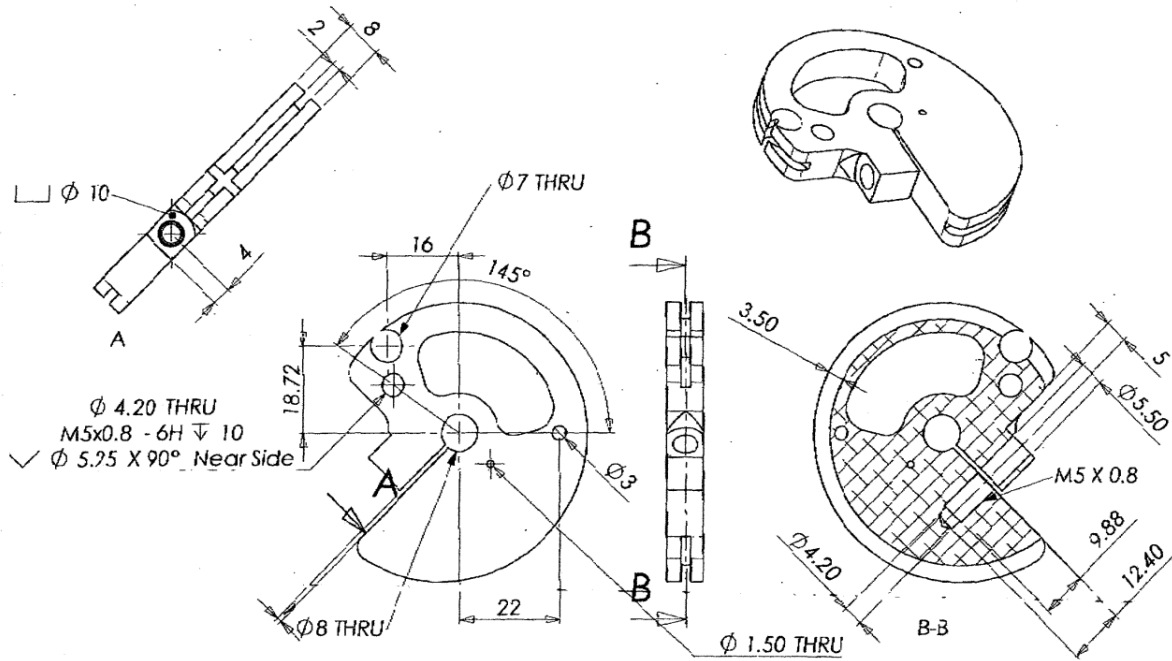

DRAWING 3: K&N AIR FILTER SN-2580

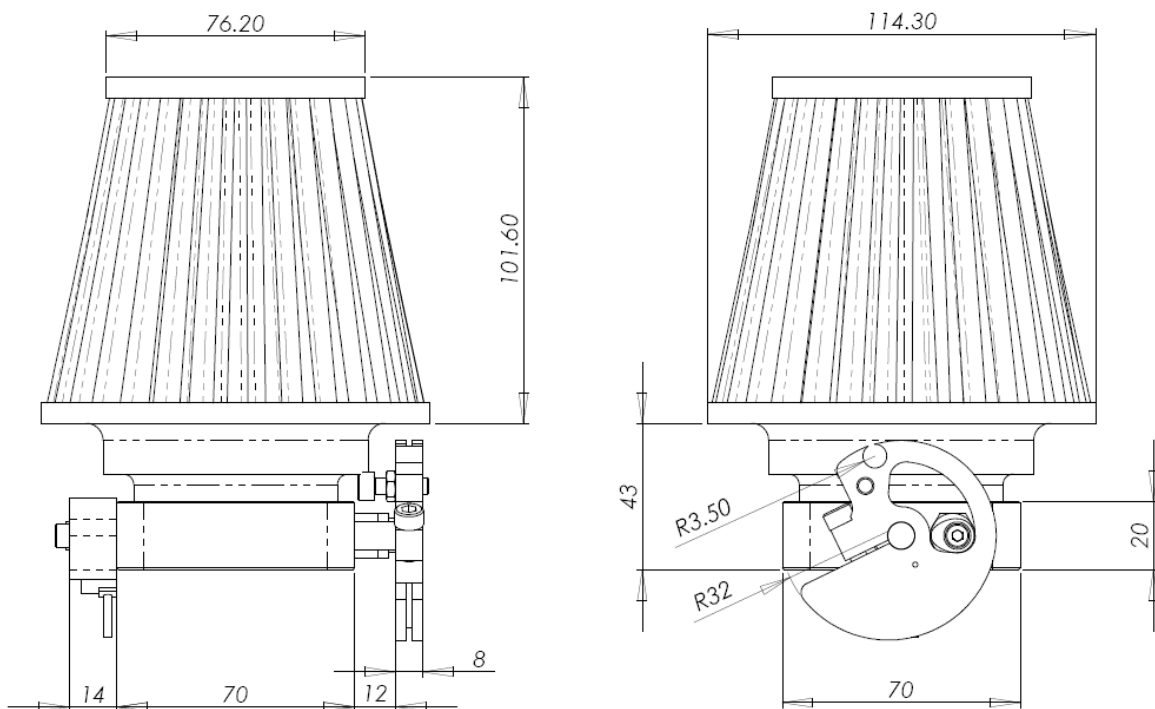

DRAWING 4: CLUTCH AND FLYWHEEL ASSEMBLY

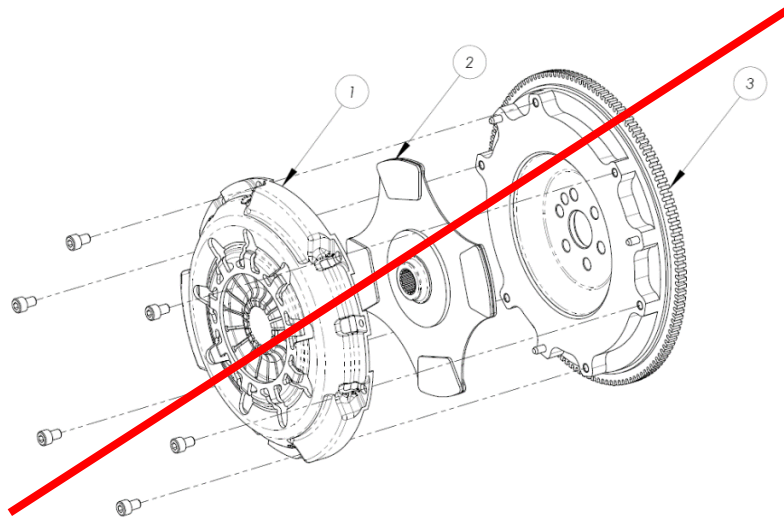

For current Flywheel and Clutch, eligible from Jan 1 2018	
1	Clutch cover – CP7371-OE90-SF
2	Driven Plate – CP2012-166FM3
3	A Flywheel – ENG000400
For alternative Flywheel and Clutch, eligible from Jan 1 2018	
1	Driven Plate – CP4429-3FM4
2	
3	

DRAWING 5: INLET MANIFOLD ASSEMBLY

5A

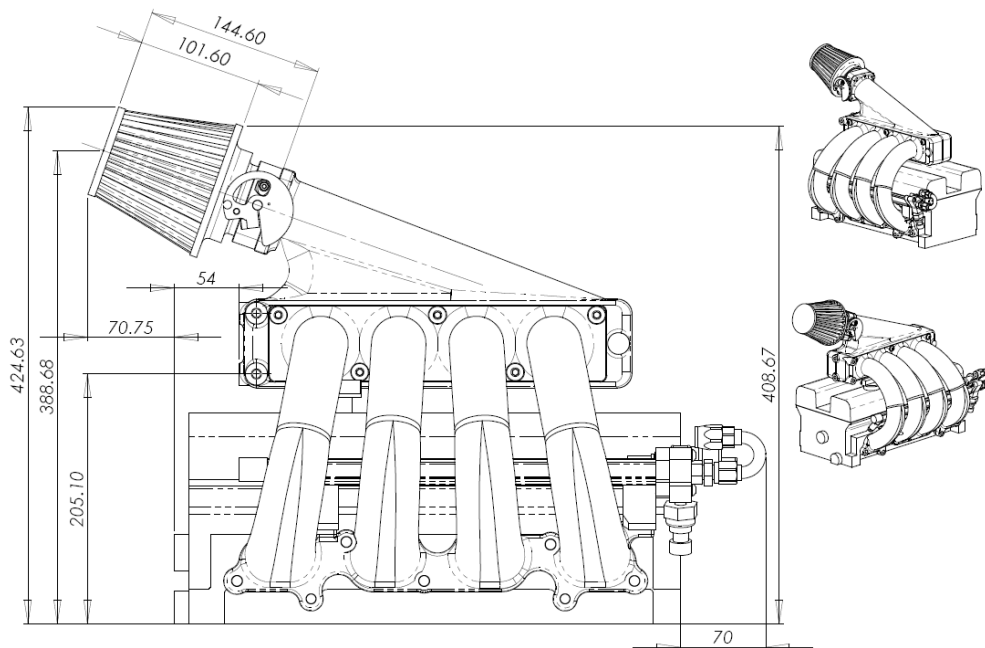

Component References	
Runners	ENG0071-A1
Plenum	ENG0071-A2

5B

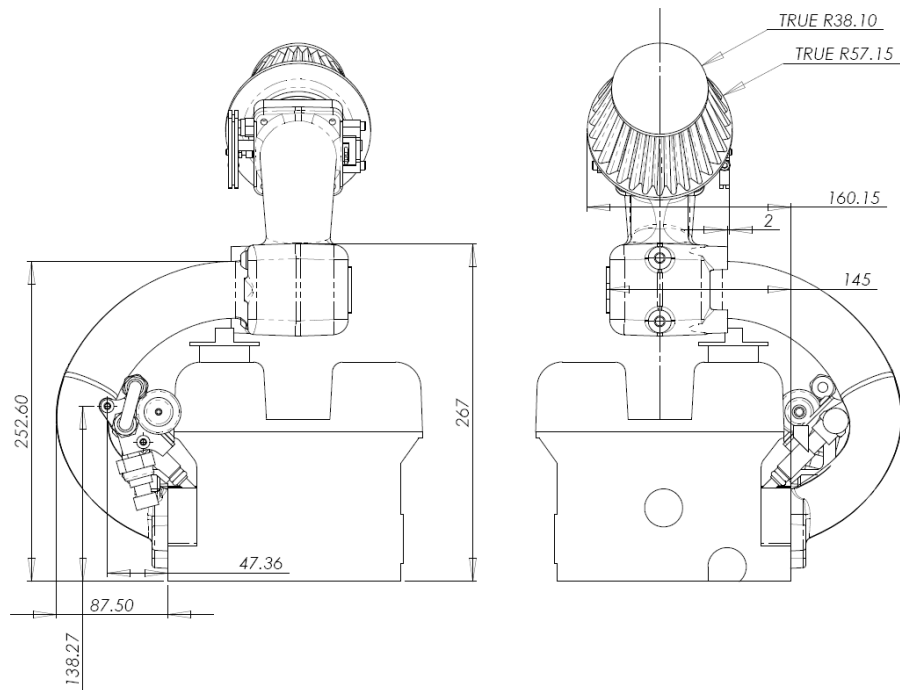

DRAWING 6: FUEL RAIL ASSEMBLY

6A

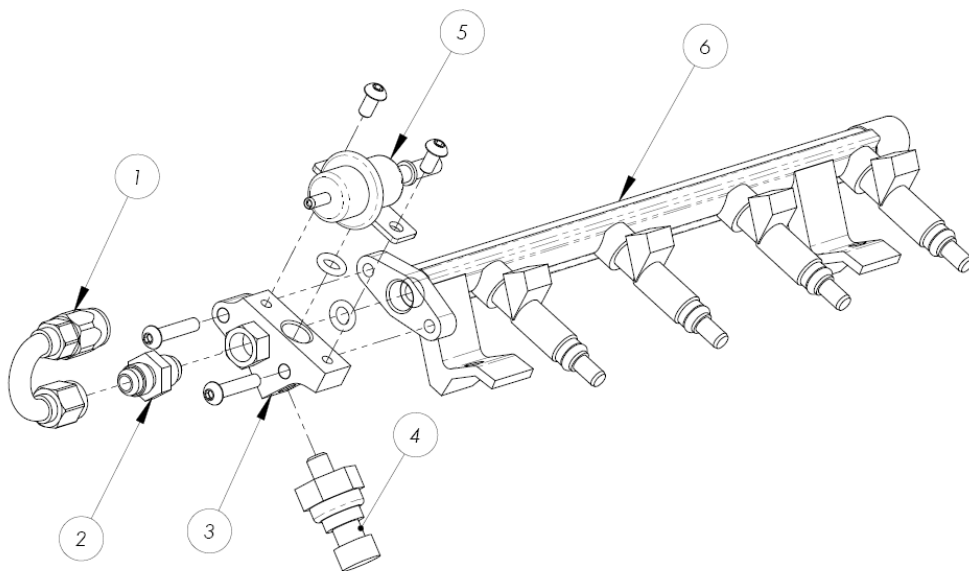

1	318006ERL Earl's hose end
2	981506ERL Earl's adapter
3	FLS0131-A Fuel supply block
4	Fuel pressure sensor
5	Fuel pressure regulator
6	Fuel Rail

6B

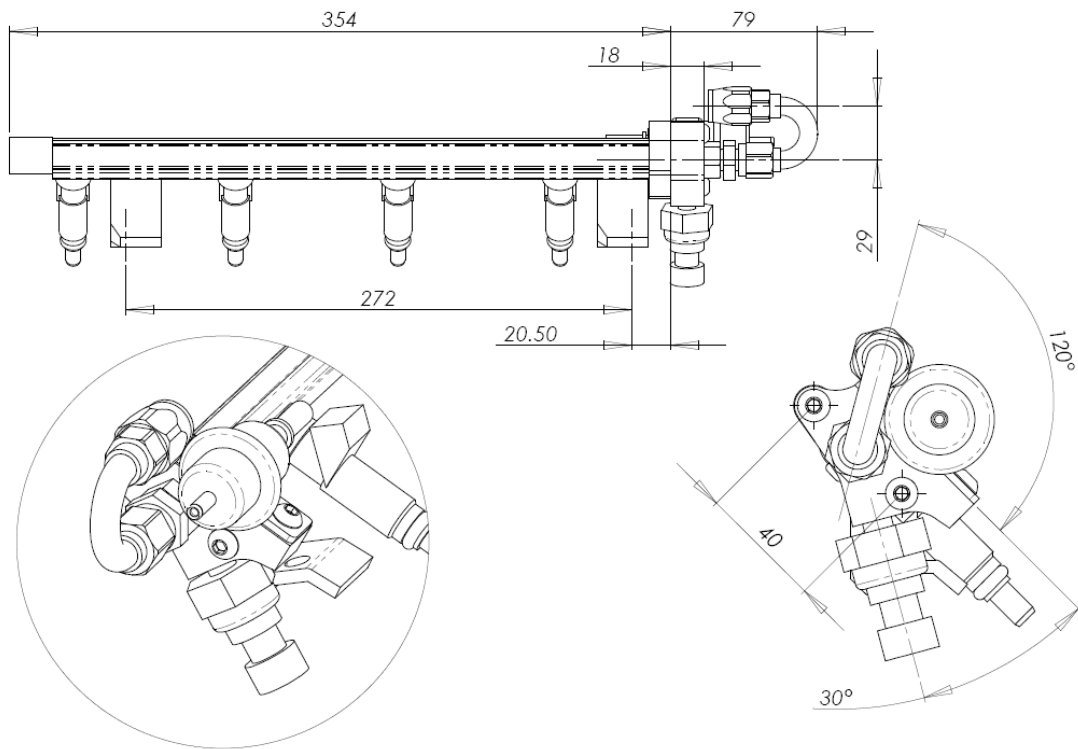

DRAWING 7: PACE COMPACT “C” SCAVENGE PUMP

7A

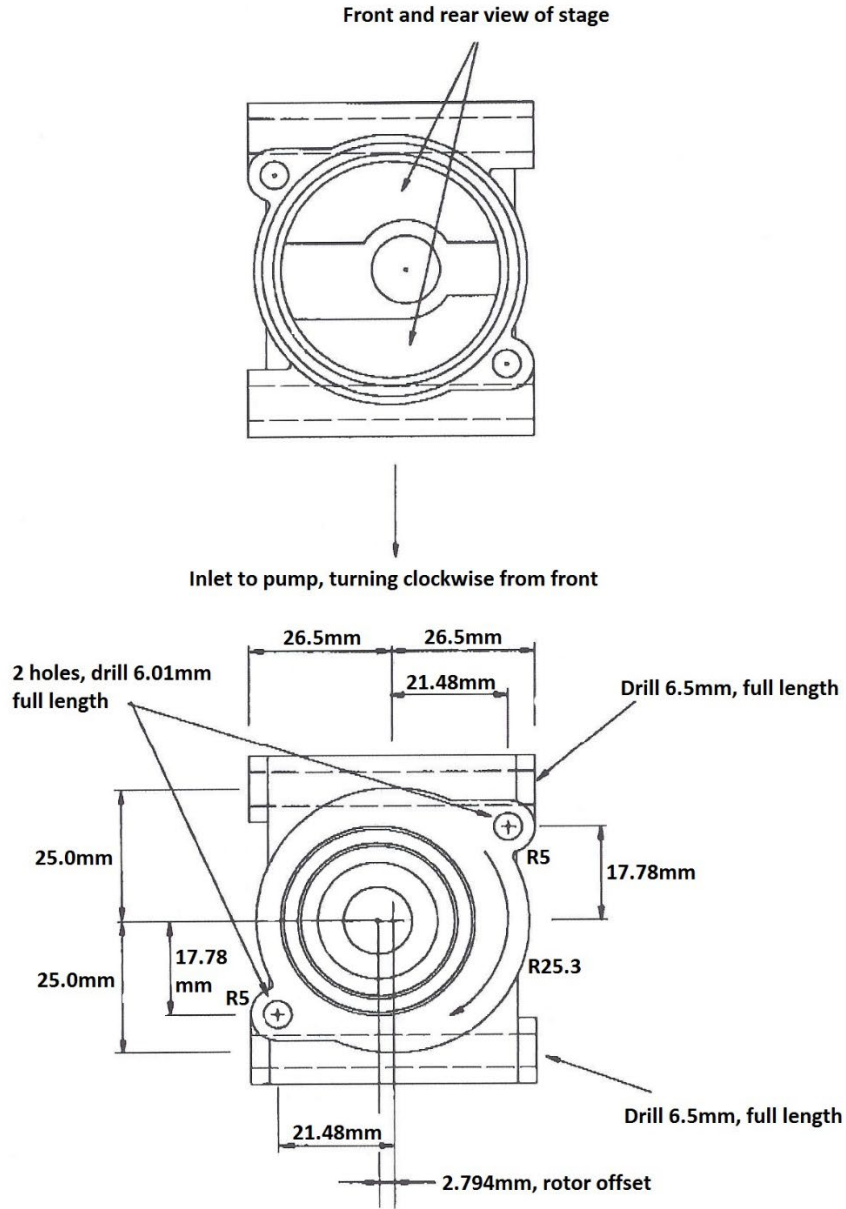

Specifications

2-stage 10-litre pure scavenge

Each stage flows 10 litres of oil per 1000 pump RPM

Max. peak RPM: 5000

7B

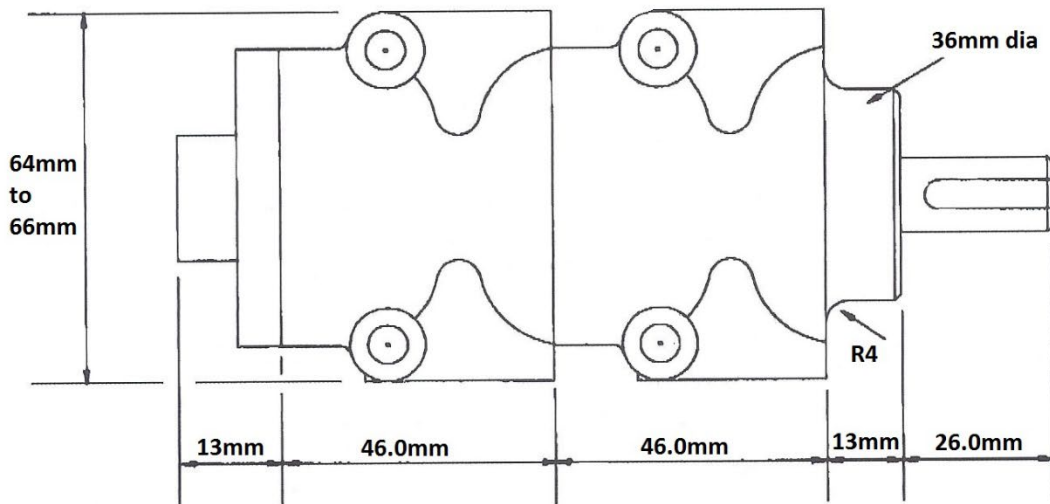
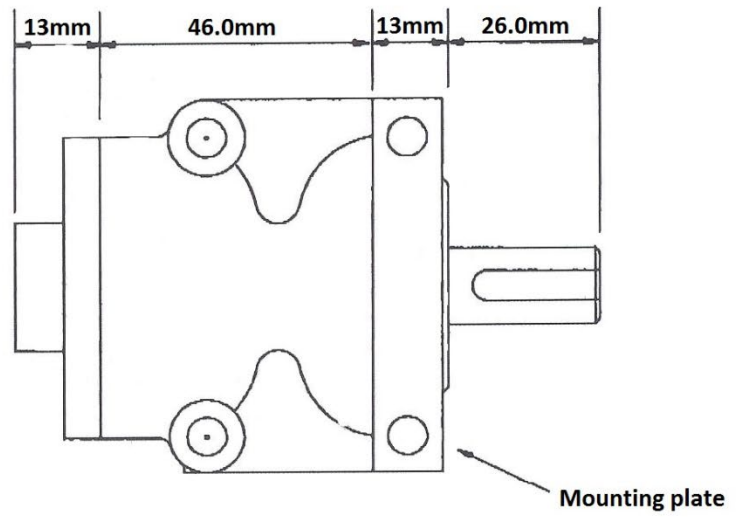
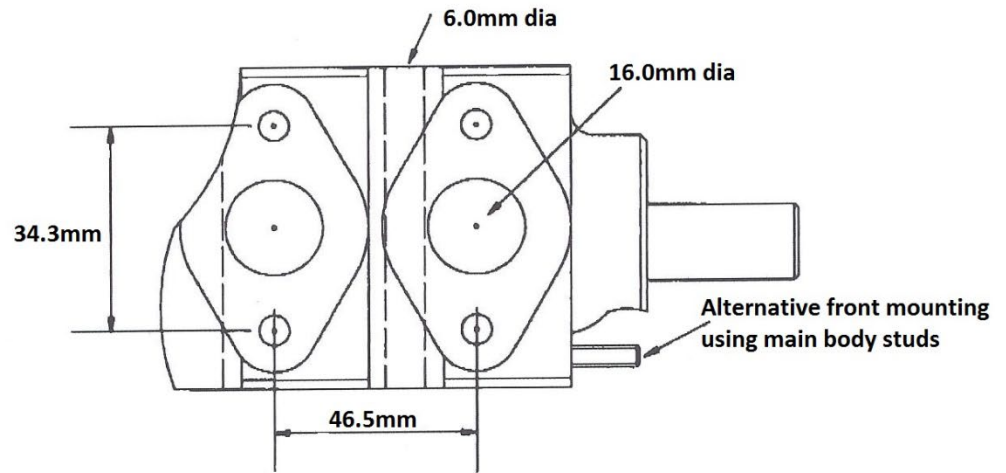

DRAWING 8: EXHAUST COLLECTOR

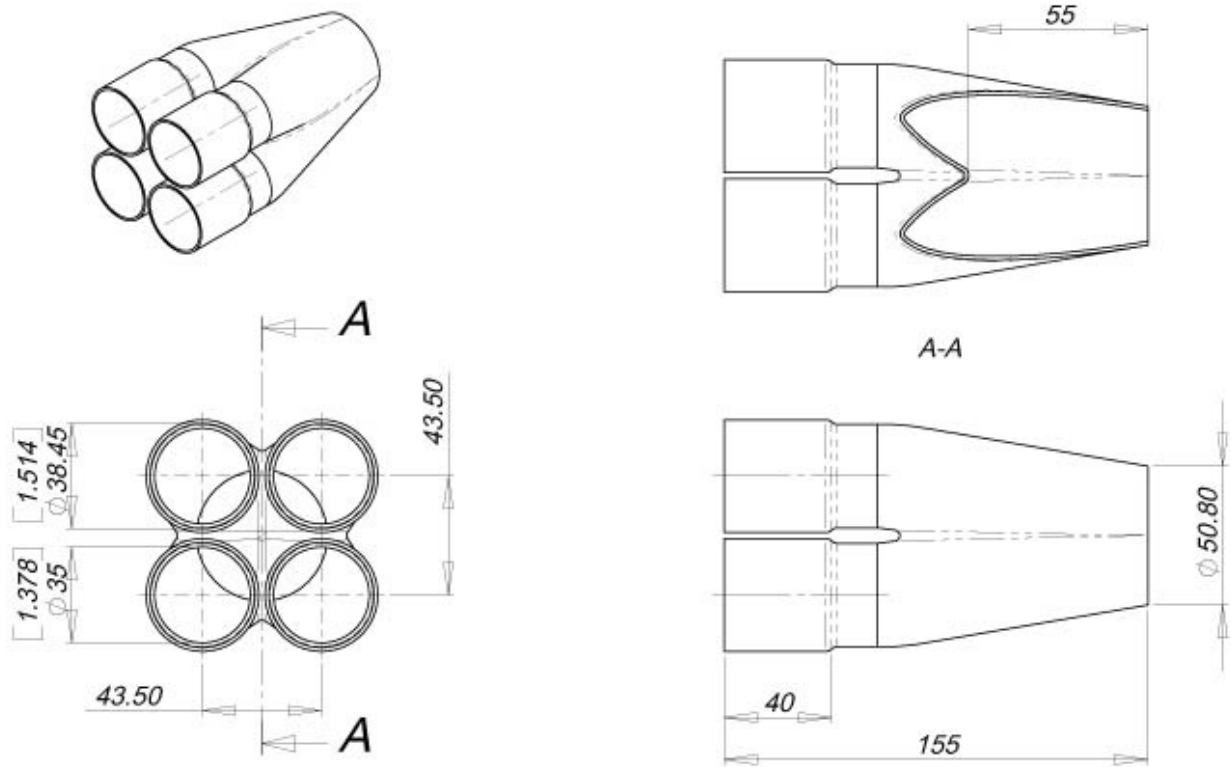

DRAWING 9: RF0B CRANK CENTRE LINE (CL) TO MOUNTING HOLES

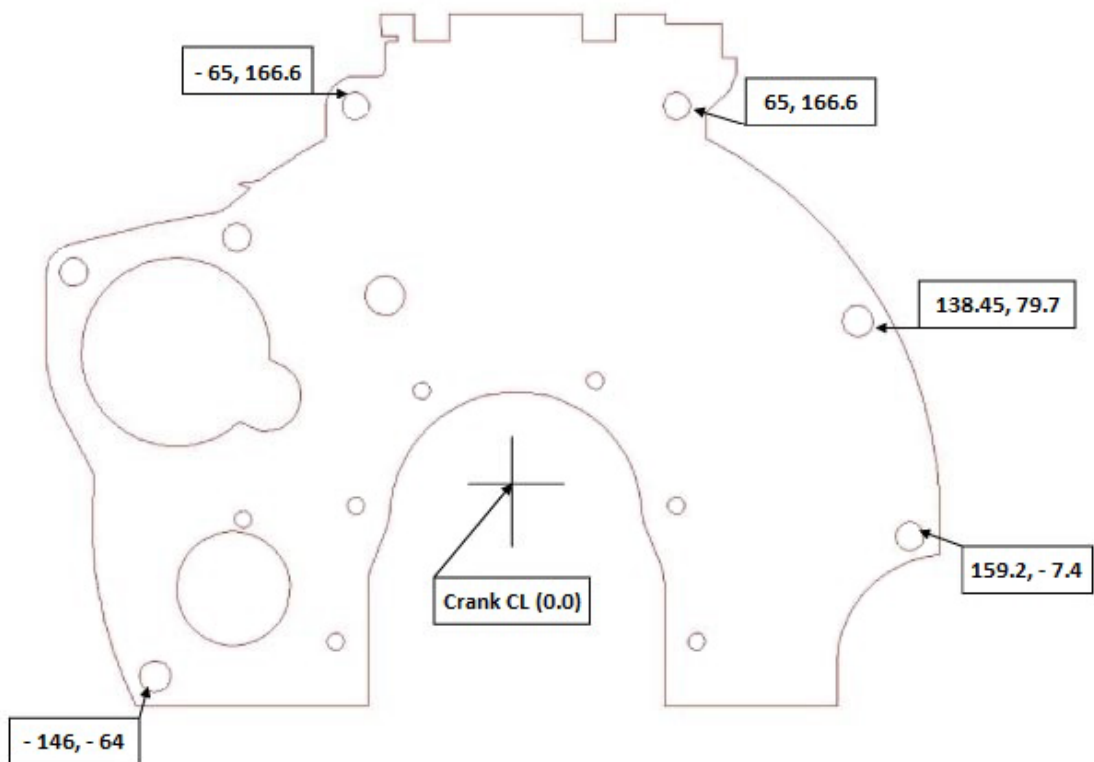

WIRING LOOM – INSTALLATION INSTRUCTIONS / GUIDE

Part No. MSE F/Ford Rev 1

Engine loom must be installed to chassis in a manner which ensures that the harness cannot rub against any hoses or components.

Ensure chassis wiring supplied to engine loom is as per Connector Pinout supplied. Connector Part No. Deutsch. DT-06-4S. This connector is available from most automotive electricians.

The fuel pump relay must be wired as per diagram supplied and an ignition switch controlled relay is the best method of power supply to the engine harness.

All Connector part numbers are on chassis diagram supplied.

Starter motor cable needs to be 3 B & S cable, not light gauge as used on most Kent engines.

The alternator power feed - min size 6mm cable - needs to be connected to the battery via the master switch.

Ignition power is acquired by Pin 1 located at the regulator connector on the back of the alternator casting. This letter 1 is cast on the back of the alternator.

The engine loom has an RS232 output from the harness. This can be wired into Pin 79 of any MoTeC dash logger. Set up information is available from your MoTeC dealer.

Wiring to non-MoTeC logging systems will require further information from your supplier. The BAUD rate for this output is 19200.

NOTE:

Your vehicle's performance will reflect the quality of your electrical installation.

Ensure that good quality relays and power supplies are used.

If you are not sure please consult an auto electrician for help.

DRAWING 10: ENGINE LOOM LAYOUT

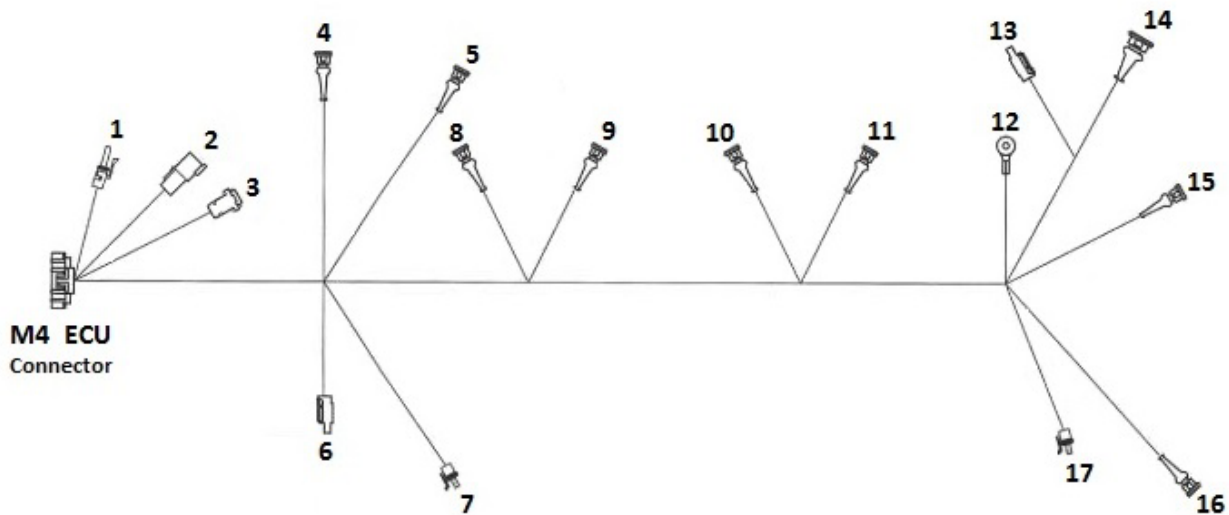

1	Map Sensor	7	Oil Pressure	13	Ignition Coil
2	Chassis Connector	8	Cylinder 1 - Injector	14	Ignition Module
3	Comms Connector	9	Cylinder 2 - Injector	15	Engine Temperature
4	Air Temperature	10	Cylinder 3 - Injector	16	REF Sensor
5	Sync Sensor	11	Cylinder 4 - Injector	17	Fuel Pressure
6	TPS Sensor	12	Engine Ground		

DRAWING 11: CHASSIS WIRING LAYOUT

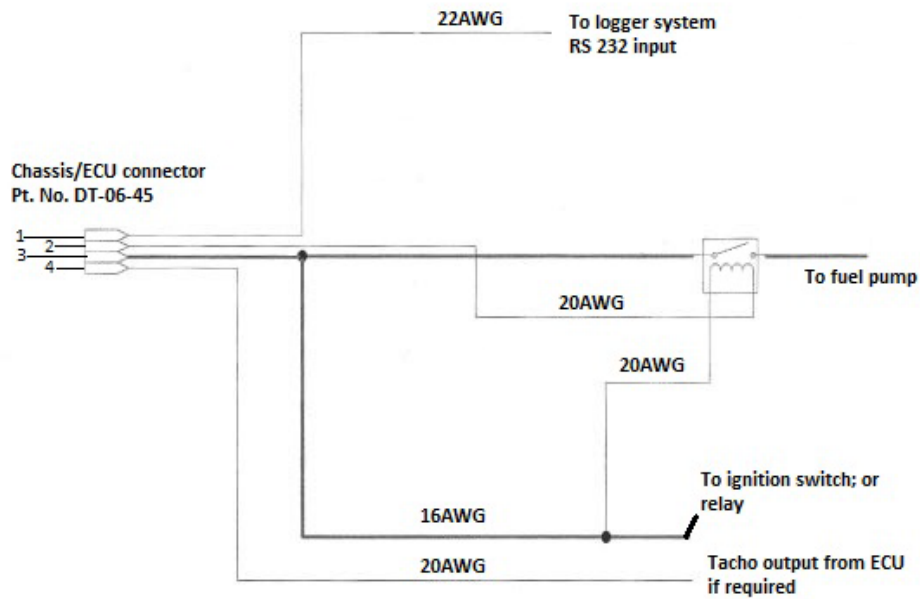

DRAWING 12: ENGINE WIRING LAYOUT

